

P-17851

S5680

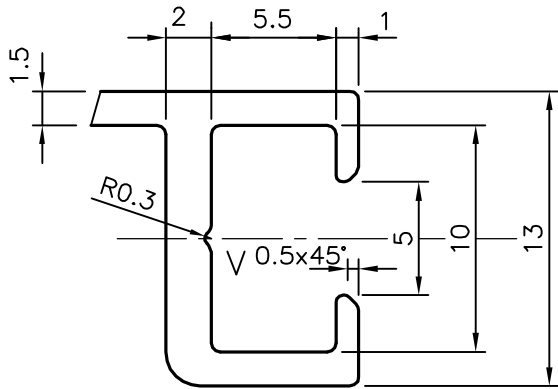

**DETAIL-B**  
SCALE 3:1

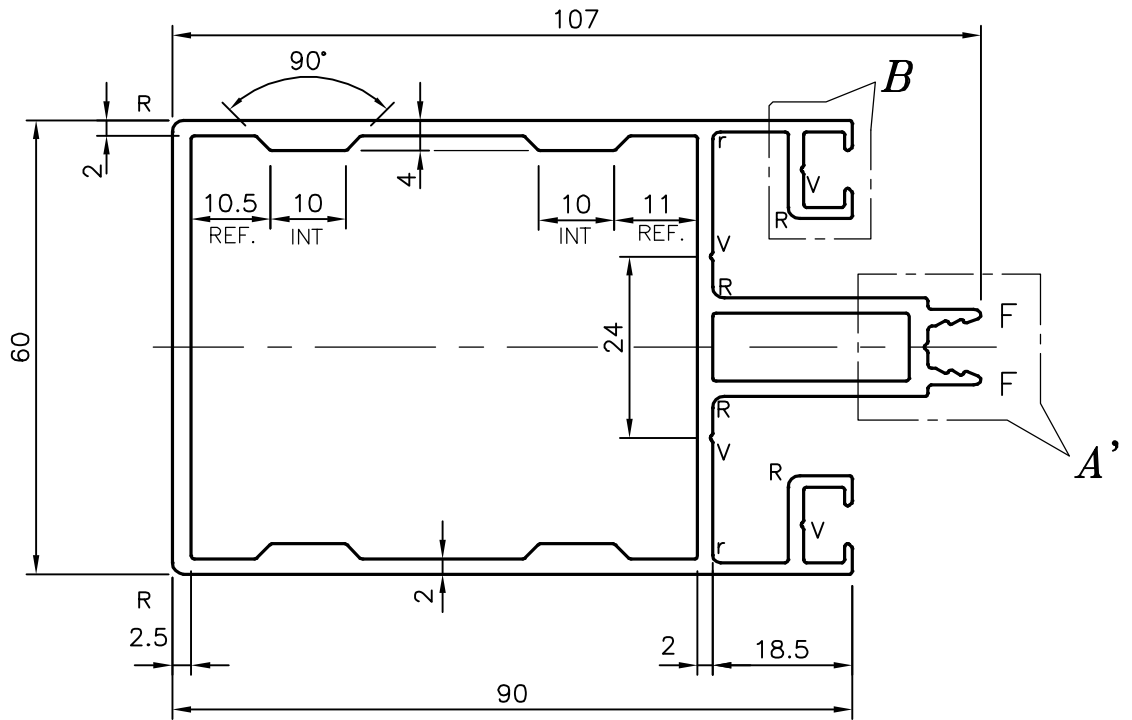
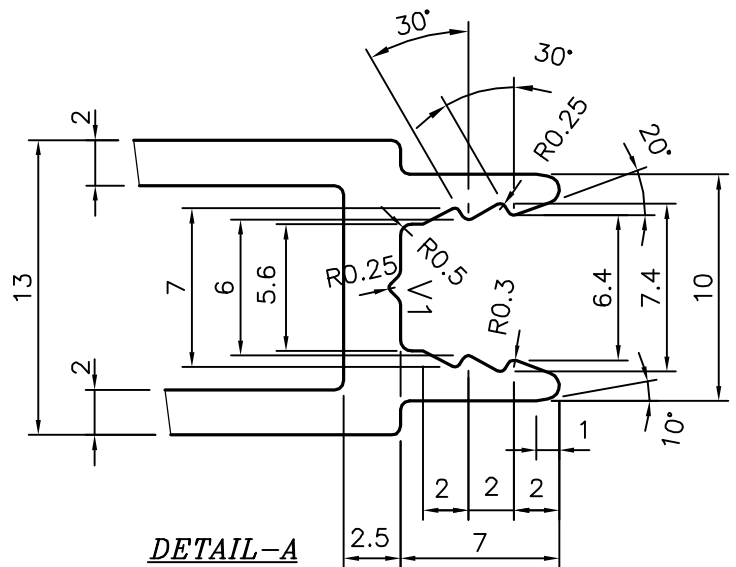

**DETAIL-A**  
SCALE 3:1

- R = R1.5 (6 PLACES)
- r = R1.0 (2 PLACES)
- V = V GROOVE 0.30x90°(4 PLACES)
- V1 = V GROOVE 0.50x90°(ONE PLACE)
- F = FULL RADIUS (2)



SYMBOL OF QUALITY  
AN ISO 9001 COMPANY

**JINDAL ALUMINIUM LTD.**  
BANGALORE-560073 (INDIA)

	NAME	DATE
DRAWN	J.P.KAUSHIK	08-02-2018
CHECKED		
APPROVED	B.NATARAJ	13-02-2018
SCALE		1:1
AREA mm <sup>2</sup>		923.552
PERIMETER mm.		503.836
WEIGHT kg/m		2.494
DRAWING No.	SECTION No.	
P-17851	-	
S5680	S5680	

1. ALL DIMENSIONS ARE IN mm.
2. ROUND OFF ALL SHARP CORNERS WITH 0.40 mm.
3. TOLERANCES WILL BE AS PER IS:6477-1983 , UNLESS OTHERWISE SPECIFIED

PARTY'S NAME	GLOBAL SYNDICATE, BANGALORE
PARTY'S DRAWING No.	AS PER DRAWING-5455
ALLOY & TEMPER	6063 T6
DESCRIPTION	MULLION SECTION