

P-18008

S5727

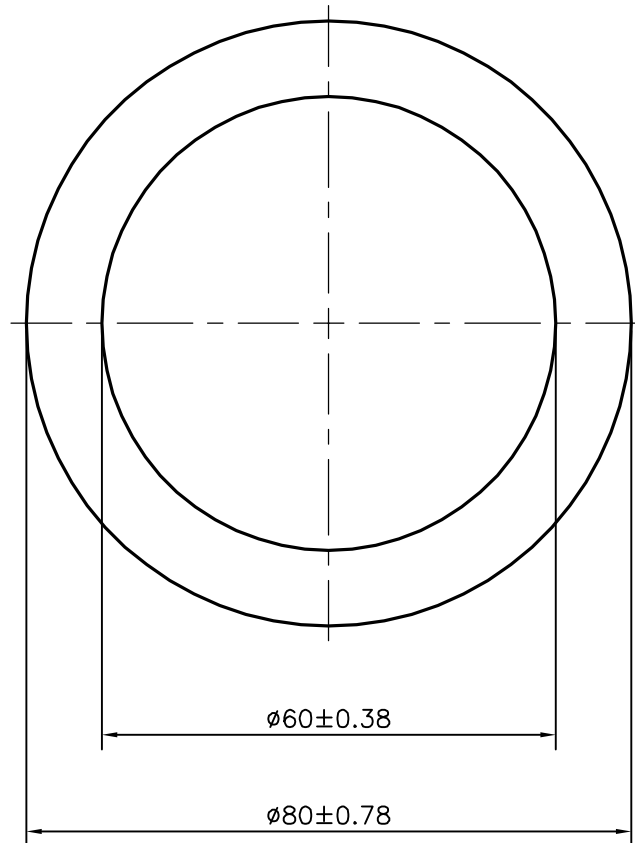

STRAIGHTNESS/METER= 0.5MAX.



SYMBOL OF QUALITY  
AN ISO 9001 COMPANY

**JINDAL ALUMINIUM LTD.**  
**BANGALORE-560073 (INDIA)**

	NAME	DATE
DRAWN	J.P.KAUSHIK	17-03-2018
CHECKED		
APPROVED	<b>B.NATARAJA</b>	19-03-2018
SCALE		1:1
AREA mm <sup>2</sup>		2199.115
PERIMETER mm.		251.327
WEIGHT kg/m		5.938
DRAWING No.	SECTION No.	
P-18008	-	
S5727	S5727	

1. ALL DIMENSIONS ARE IN mm.
2. ROUND OFF ALL SHARP CORNERS WITH 0.40 mm.
3. TOLERANCES WILL BE AS PER IS:2673-2002 , UNLESS OTHERWISE SPECIFIED

PARTY'S NAME	RABWIN INDUSTRIES PVT. LTD., COIMBATORE
PARTY'S DRAWING No.	3-805-18-3291
ALLOY & TEMPER	6063 T6
DESCRIPTION	ROUND TUBE