

P-18094-1

S5778

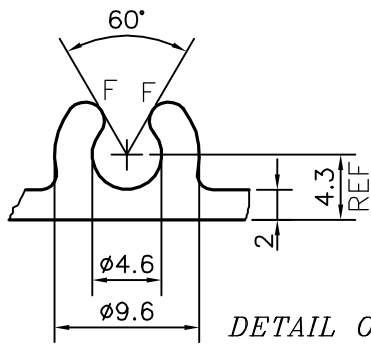

DETAIL OF "A"
SCALE 2:1

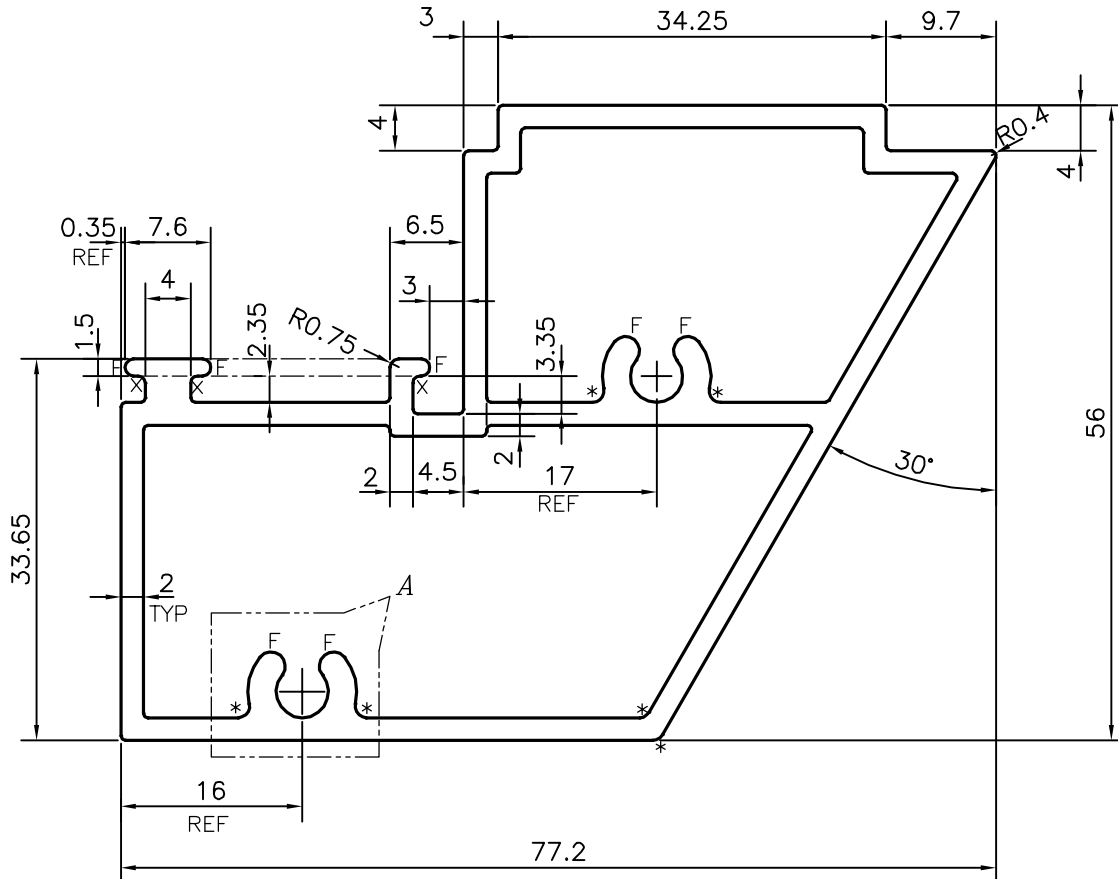
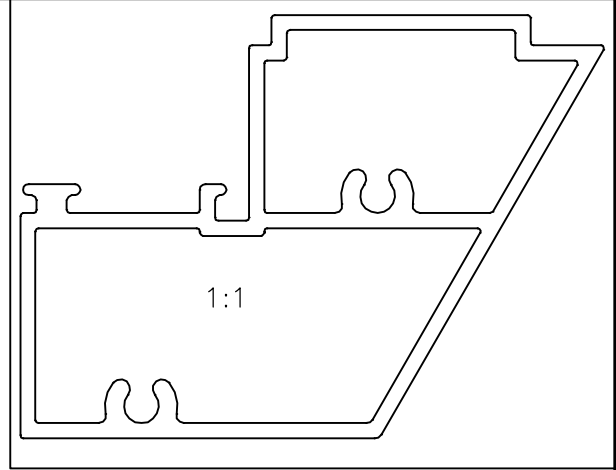

X = 0.65 RADIUS (3 PLACES)
 * = 1.0 RADIUS (6 PLACES)
 F = FULL RADIUS (7 PLACES)



SYMBOL OF QUALITY
AN ISO 9001 COMPANY

JINDAL ALUMINIUM LTD.
BANGALORE-560073 (INDIA)

	NAME	DATE
DRAWN	J.P.KAUSHIK	16-04-2018
CHECKED		
APPROVED	B.NATARAJA	18-04-2018
SCALE		1.5:1
AREA mm ²		628.086
PERIMETER mm.		266.802
WEIGHT kg/m		1.696
DRAWING No.	SECTION No.	
P-18094-1	-	
S5778	S5778	

1. ALL DIMENSIONS ARE IN mm.
2. ROUND OFF ALL SHARP CORNERS WITH 0.40 mm.
3. TOLERANCES WILL BE AS PER IS:6477-1983 , UNLESS OTHERWISE SPECIFIED

PARTY'S NAME	GLOBAL SYNDICATE, BANGALORE
PARTY'S DRAWING No.	AS PER DRAWING
ALLOY & TEMPER	6063 T6
DESCRIPTION	NOSE FOR TRANSOM SECTION