

P-18083

S5779

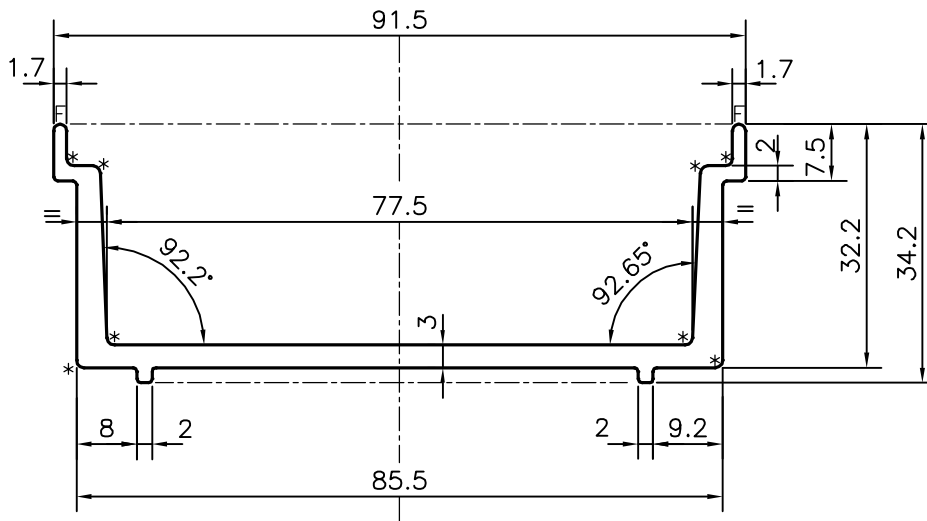

* = 1.0 RADIUS (8 PLACES)
 F = FULL RADIUS(2 PLACES)

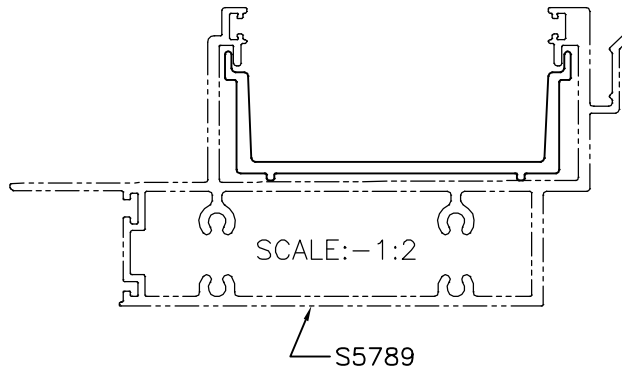

SYMBOL OF QUALITY
 AN ISO 9001 COMPANY

JINDAL ALUMINIUM LTD.
 BANGALORE-560073 (INDIA)

	NAME	DATE
DRAWN	J.P.KAUSHIK	13-04-2018
CHECKED		
APPROVED	B.NATARAJA	19-04-2018
SCALE		1:1
AREA	mm ²	462.357
PERIMETER	mm.	304.53
WEIGHT	kg/m	1.248
DRAWING No.	SECTION No.	
P-18083	-	
S5779	S5779	

1. ALL DIMENSIONS ARE IN mm.
2. ROUND OFF ALL SHARP CORNERS WITH 0.40 mm.
3. TOLERANCES WILL BE AS PER IS:3965-1981 , UNLESS OTHERWISE SPECIFIED

PARTY'S NAME	GLOBAL SYNDICATE, BANGALORE
PARTY'S DRAWING No.	AS PER DRAWING
ALLOY & TEMPER	6063 T6
DESCRIPTION	GUTTER SECTION