

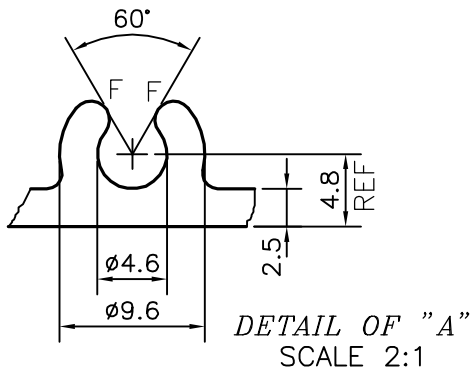

P-18088-1

S5784

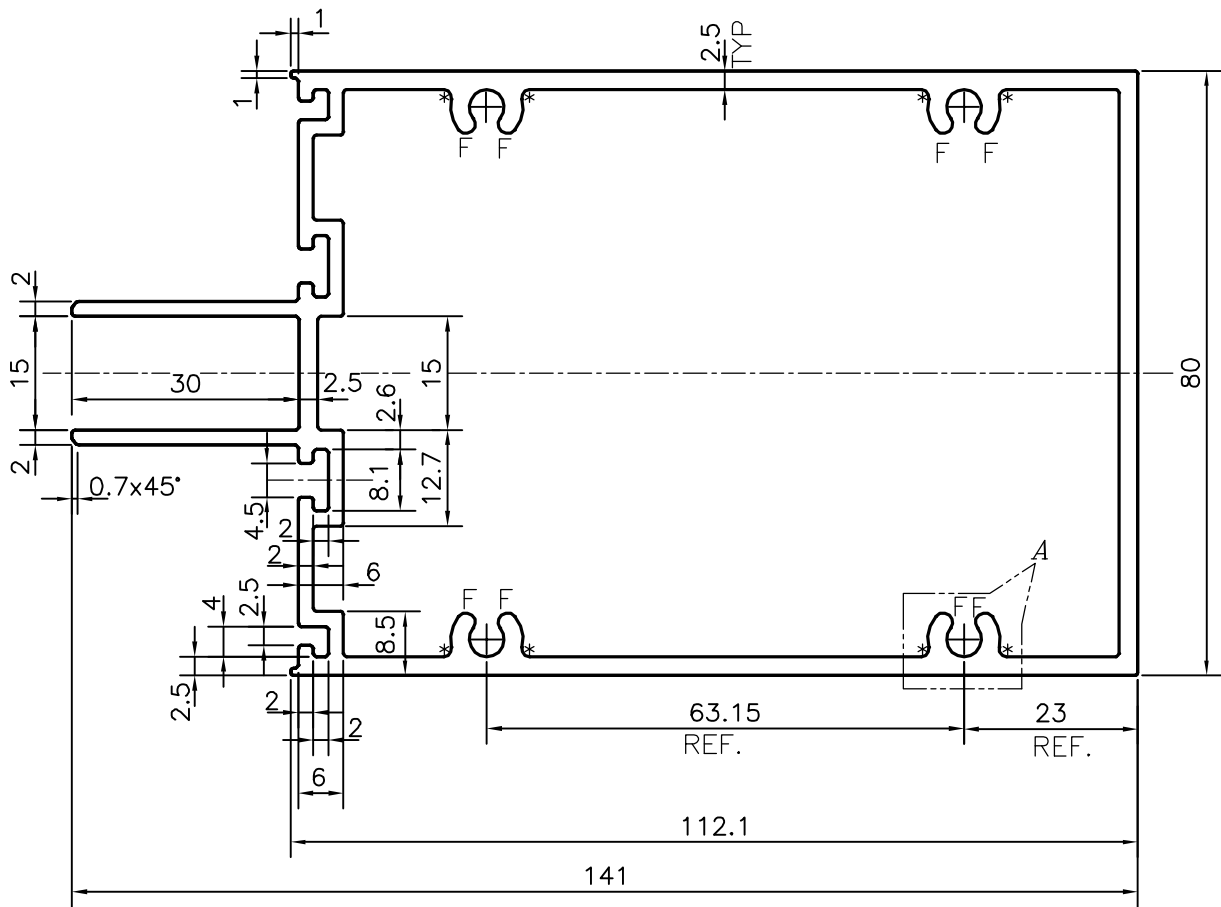

\* = 1.0 RADIUS (8 PLACES)  
F = FULL RADIUS(8 PLACES)

 SYMBOL OF QUALITY AN ISO 9001 COMPANY	<b>JINDAL ALUMINIUM LTD.</b> BANGALORE-560073 (INDIA)	NAME	DATE
		DRAWN	J.P.KAUSHIK 14-04-2018
1. ALL DIMENSIONS ARE IN mm. 2. ROUND OFF ALL SHARP CORNERS WITH 0.40 mm. 3. TOLERANCES WILL BE AS PER IS:6477-1983 , UNLESS OTHERWISE SPECIFIED		CHECKED	
		APPROVED	B.NATARAJA 19-04-2018
PARTY'S NAME GLOBAL SYNDICATE, BANGALORE		SCALE	1:1
		AREA mm <sup>2</sup>	1218.323
PARTY'S DRAWING No. AS PER DRAWING-TYPE 01		PERIMETER mm.	550.3
		WEIGHT kg/m	3.289
ALLOY & TEMPER 6063 T6		DRAWING No.	SECTION No.
		P-18088-1	-
DESCRIPTION HEAD TRANSOM SECTION		S5784	S5784