

P-18104

S5796

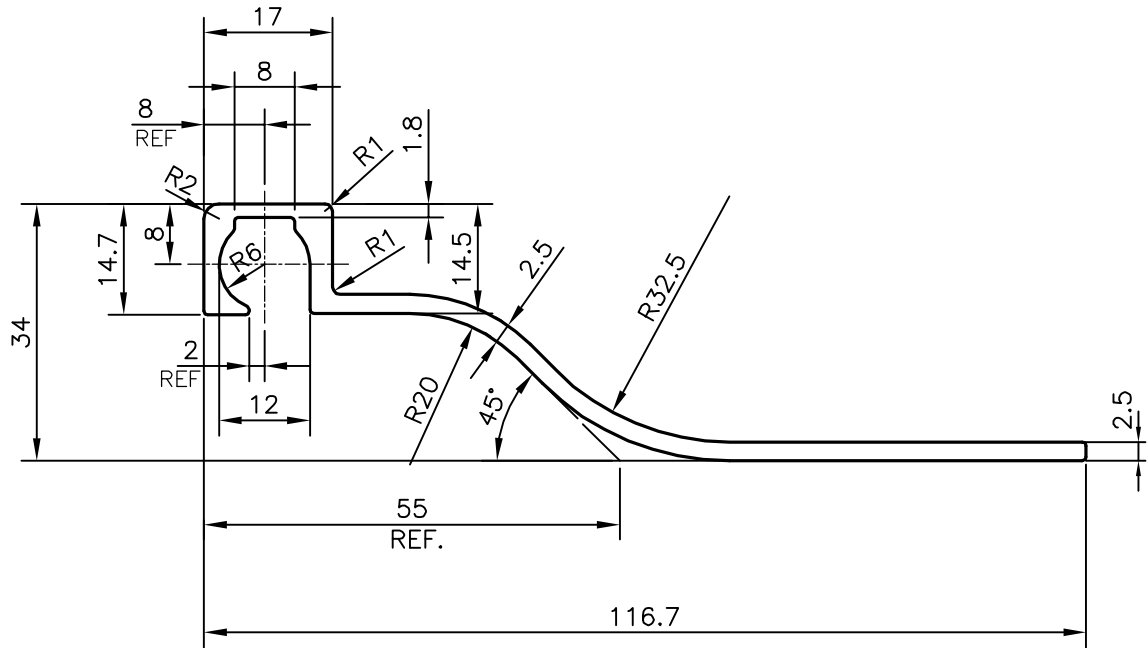

UNSPECIFIED CORNER RADII = 0.50 mm



SYMBOL OF QUALITY
AN ISO 9001 COMPANY

JINDAL ALUMINIUM LTD.
BANGALORE-560073 (INDIA)

	NAME	DATE
DRAWN	J.P.KAUSHIK	13-04-2018
CHECKED		
APPROVED	B.NATARAJA	24-04-2018
SCALE		1:1
AREA mm ²		379.684
PERIMETER mm.		299.145
WEIGHT kg/m		1.025
DRAWING No.	SECTION No.	
P-18104	-	
S5796	S5796	

1. ALL DIMENSIONS ARE IN mm.
2. ROUND OFF ALL SHARP CORNERS WITH 0.40 mm.
3. TOLERANCES WILL BE AS PER IS:3965-1981 , UNLESS OTHERWISE SPECIFIED

PARTY'S NAME	HANSPAL TRADERS, KAPURTHALA
PARTY'S DRAWING No.	AS PER DRAWING
ALLOY & TEMPER	6063 T6
DESCRIPTION	COVER PROFILE