

P-14591-2

S5823

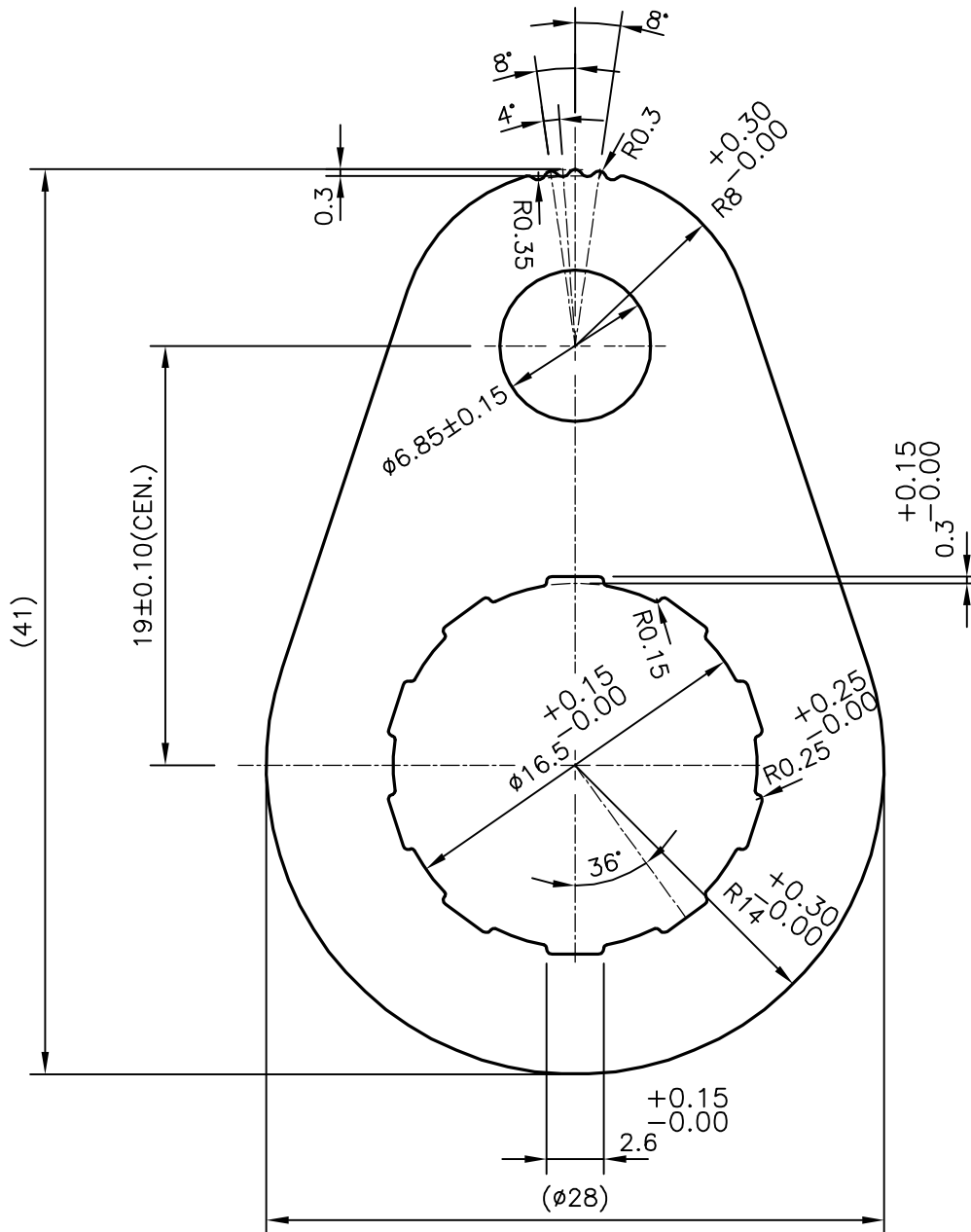
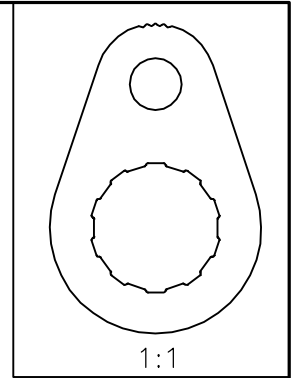

SYMBOL OF QUALITY
AN ISO 9001 COMPANY

JINDAL ALUMINIUM LTD.
BANGALORE-560073 (INDIA)

	NAME	DATE
DRAWN	J.P.KAUSHIK	05-05-2018
CHECKED		
APPROVED	B.NATARAJA	18-05-2018
SCALE		3:1
AREA mm ²		587.584
PERIMETER mm.		109.769
WEIGHT kg/m		1.586
DRAWING No.	SECTION No.	
P-14591-2	-	
S5823	S5823	

1. ALL DIMENSIONS ARE IN mm.
2. ROUND OFF ALL SHARP CORNERS WITH 0.40 mm.
3. TOLERANCES WILL BE AS PER IS:6477-1983 UNLESS OTHERWISE SPECIFIED

PARTY'S NAME	WINTAGE ENGINEERS & CONSULTANTS, GHAZIABAD
PARTY'S DRAWING No.	ALFP1621
ALLOY & TEMPER	6060 T6
DESCRIPTION	MISC. SECTION