

P-18192

S5832

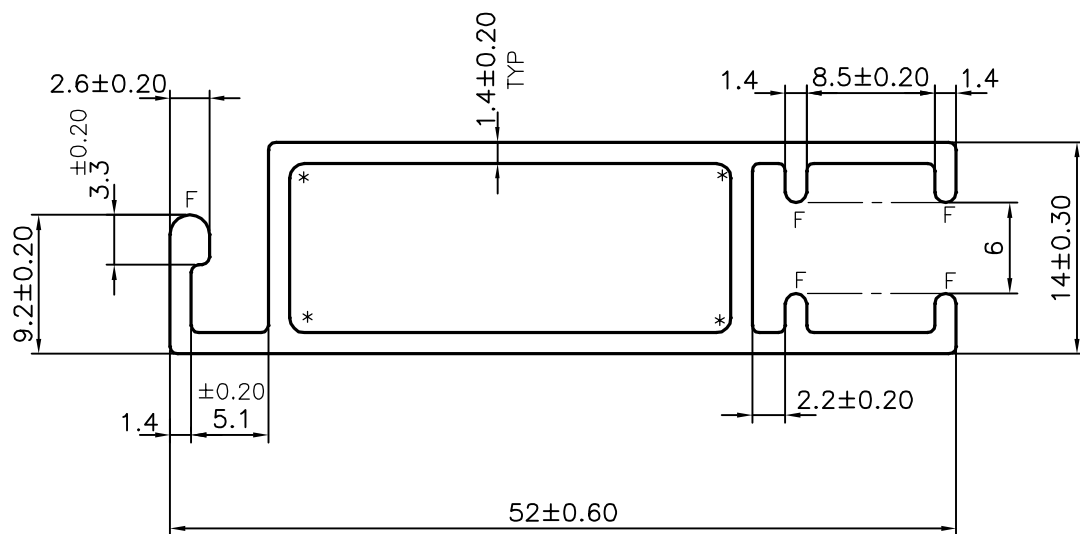
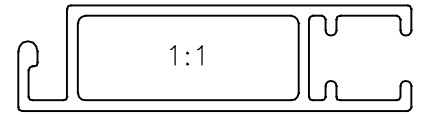

UNSPECIFIED RADIUS 0.5 mm

F = FULL RADIUS (5 PLACES)
 * = 1.0 RADIUS (4 PLACES)

TOLERANCES ON OVERALL DIMENSIONS OF HOLLOW SECTIONS

UPTO 20.0mm - ±0.30	UPTO 80.0mm - ±0.70	UPTO 180.0mm - ±1.27	1. STRAIGHTNESS=1.7mm/M 2. TWIST=1.7mm/M 3. ANGULARITY= ±2° 4. FLATNESS =0.006xWIDTH
UPTO 30.0mm - ±0.38	UPTO 100.0mm - ±0.80	UPTO 200.0mm - ±1.40	
UPTO 40.0mm - ±0.45	UPTO 120.0mm - ±0.90	UPTO 225.0mm - ±1.52	
UPTO 50.0mm - ±0.52	UPTO 140.0mm - ±1.00		
UPTO 60.0mm - ±0.60	UPTO 160.0mm - ±1.14		



SYMBOL OF QUALITY
AN ISO 9001 COMPANY

JINDAL ALUMINIUM LTD.
 BANGALORE-560073 (INDIA)

	NAME	DATE
DRAWN	J.P.KAUSHIK	14-05-2018
CHECKED		
APPROVED	B.NATARAJA	28-05-2018

- ALL DIMENSIONS ARE IN mm.
- ROUND OFF ALL SHARP CORNERS WITH 0.40 mm.
- TOLERANCES WILL BE AS PER,IS:6477-1983 UNLESS OTHERWISE SPECIFIED

SCALE	2:1
AREA mm ²	196.914
PERIMETER mm.	190.847
WEIGHT kg/m	0.532

PARTY'S NAME	GLASS WALL SYSTEMS INDIA PVT. LTD., MUMBAI	DRAWING No.	SECTION No.
PARTY'S DRAWING No.	AS PER DRAWING-5310	P-18192	-
ALLOY & TEMPER	6063 T6	S5832	S5832
DESCRIPTION	FLY SCREEN SECTION		