

P-18194

S5834

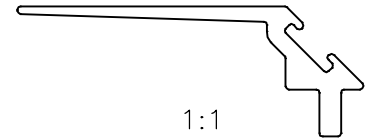

1:1

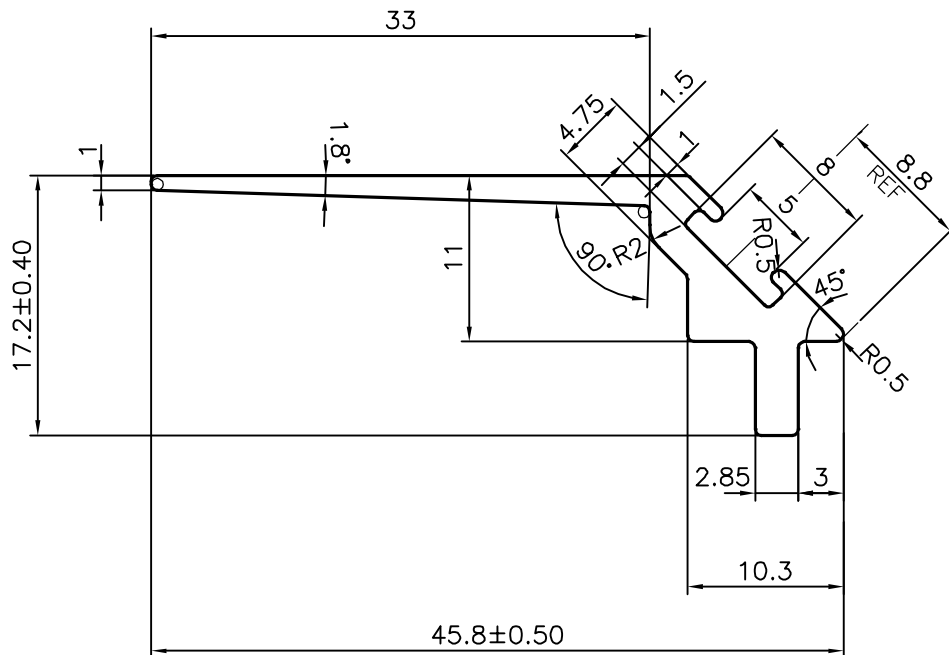

TOLERANCES ON OVERALL DIMENSIONS OF HOLLOW SECTIONS

UPTO 20.0mm - ±0.30
 UPTO 30.0mm - ±0.38
 UPTO 40.0mm - ±0.45
 UPTO 50.0mm - ±0.52
 UPTO 60.0mm - ±0.60

UPTO 80.0mm - ±0.70
 UPTO 100.0mm - ±0.80
 UPTO 120.0mm - ±0.90
 UPTO 140.0mm - ±1.00
 UPTO 160.0mm - ±1.14

UPTO 180.0mm - ±1.27
 UPTO 200.0mm - ±1.40
 UPTO 225.0mm - ±1.52

1. STRAIGHTNESS=1.7mm/M
 2. TWIST=1.7mm/M
 3. ANGULARITY= ±2°
 4. FLATNESS =0.006xWIDTH



SYMBOL OF QUALITY
 AN ISO 9001 COMPANY

JINDAL ALUMINIUM LTD.
 BANGALORE-560073 (INDIA)

	NAME	DATE
DRAWN	J.P.KAUSHIK	11-05-2018
CHECKED		
APPROVED	B.NATARAJA	28-05-2018

- ALL DIMENSIONS ARE IN mm.
- ROUND OFF ALL SHARP CORNERS WITH 0.40 mm.
- TOLERANCES WILL BE AS PER,IS:3965-1981 UNLESS OTHERWISE SPECIFIED

SCALE	2:1
AREA mm ²	124.138
PERIMETER mm.	125.333
WEIGHT kg/m	0.335

PARTY'S NAME	GLASS WALL SYSTEMS INDIA PVT. LTD., MUMBAI
PARTY'S DRAWING No.	AS PER DRAWING-95170
ALLOY & TEMPER	6063 T6
DESCRIPTION	CURTAIN WALL SECTION SECTION

DRAWING No.	SECTION No.
P-18194	-
S5834	S5834