

P-18255

S5876

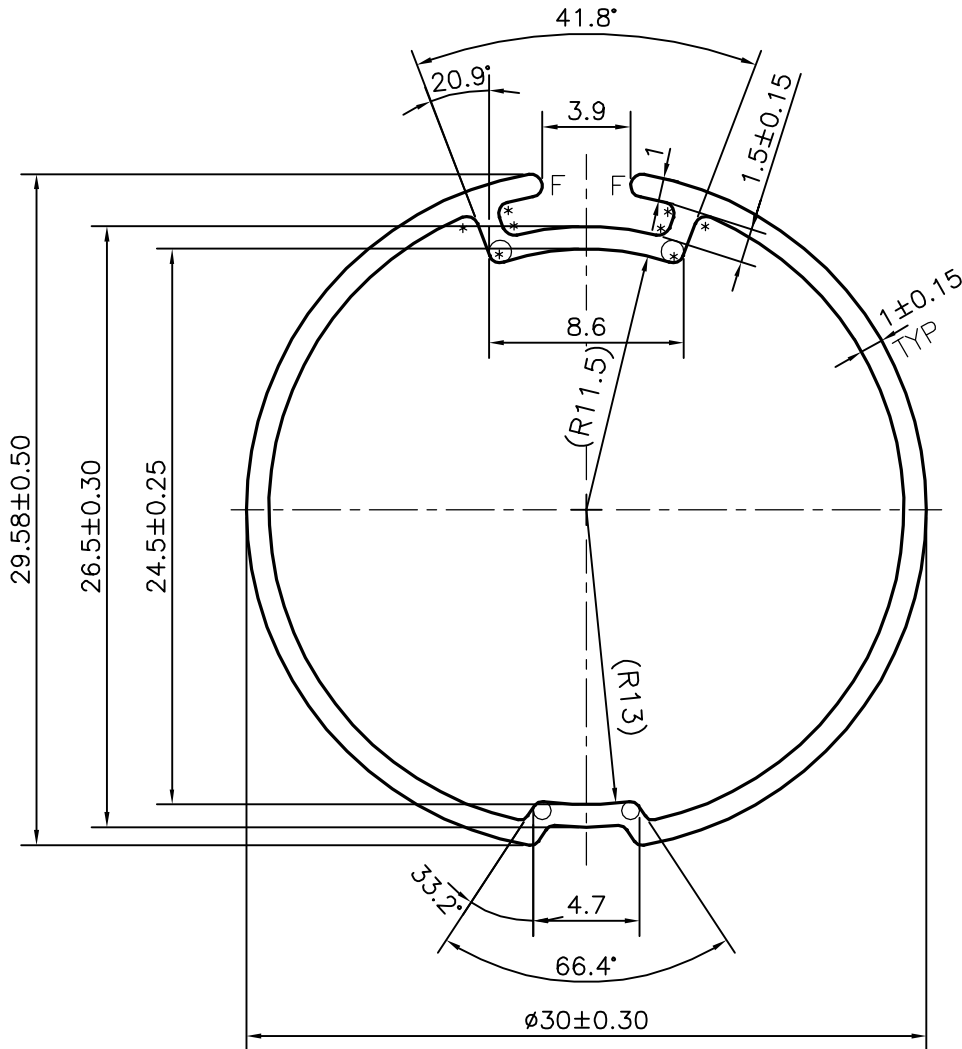
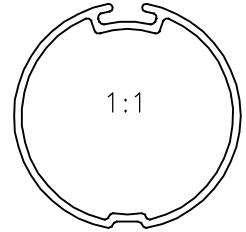

* = 0.5 mm RADIUS (6 PLACES)
 F = FULL RADIUS (2 PLACES)

TOLERANCES ON OVERALL WIDTHS & WIDTHS ACROSS FLATS OF BARS, & REGULAR SECTIONS

| | | | |
|---------------------|----------------------|----------------------|-----------------------|
| UPTO 6.40mm - ±0.20 | UPTO 32.0mm - ±0.38 | UPTO 120.0mm - ±0.85 | UPTO 320.00mm - ±1.70 |
| UPTO 10.0mm - ±0.23 | UPTO 50.0mm - ±0.46 | UPTO 160.0mm - ±1.02 | |
| UPTO 12.0mm - ±0.25 | UPTO 60.0mm - ±0.53 | UPTO 200.0mm - ±1.14 | |
| UPTO 16.0mm - ±0.28 | UPTO 80.0mm - ±0.69 | UPTO 250.0mm - ±1.40 | |
| UPTO 25.0mm - ±0.30 | UPTO 100.0mm - ±0.75 | UPTO 300.0mm - ±1.65 | |



SYMBOL OF QUALITY
 AN ISO 9001 COMPANY

JINDAL ALUMINIUM LTD.
 BANGALORE-560073 (INDIA)

| | | |
|----------|-------------|------------|
| | NAME | DATE |
| DRAWN | J.P.KAUSHIK | 22-05-2018 |
| CHECKED | | |
| APPROVED | B.NATARAJA | 01-06-2018 |

1. ALL DIMENSIONS ARE IN mm.
2. ROUND OFF ALL SHARP CORNERS WITH 0.40 mm.
3. TOLERANCES WILL BE AS PER, IS:6477-1983 UNLESS OTHERWISE SPECIFIED

| | |
|----------------------|---------|
| SCALE | 3:1 |
| AREA mm ² | 99.915 |
| PERIMETER mm. | 105.742 |
| WEIGHT kg/m | 0.270 |

| | |
|---------------------|---|
| PARTY'S NAME | JAYANITA EXPORTS PVT. LTD., GREATER NOIDA |
| PARTY'S DRAWING No. | AS PER DRAWING (153349) |
| ALLOY & TEMPER | 6063 T6 |
| DESCRIPTION | VENETIAN BLIND SECTION |

| | |
|-------------|-------------|
| DRAWING No. | SECTION No. |
| P-18255 | - |
| S5876 | S5876 |