

P-18382-1

S5927

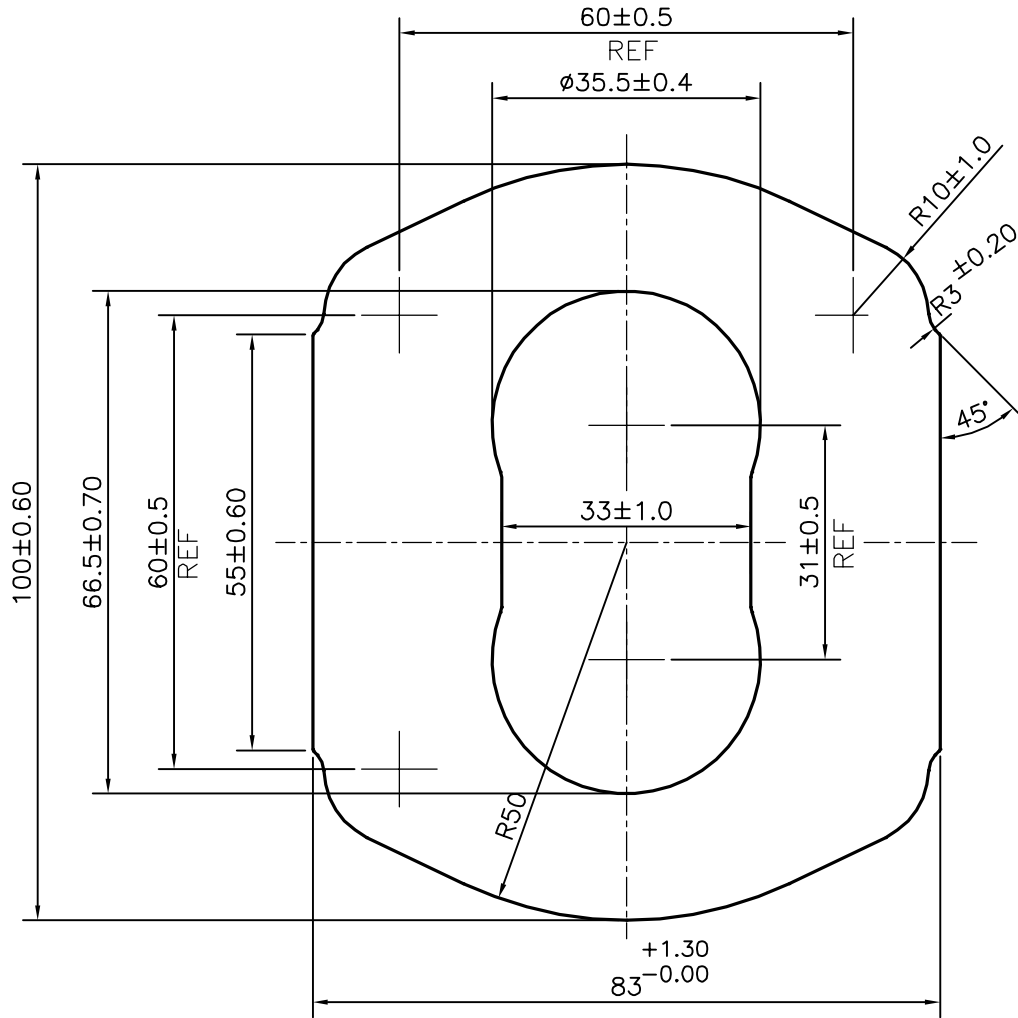

SYMBOL OF QUALITY
AN ISO 9001 COMPANY

JINDAL ALUMINIUM LTD.
BANGALORE-560073 (INDIA)

	NAME	DATE
DRAWN	J.P.KAUSHIK	09-07-2018
CHECKED		
APPROVED	B.NATARAJA	17-07-2018
SCALE		1:1
AREA mm ²		5285.36
PERIMETER mm.		312.594
WEIGHT kg/m		14.270
DRAWING No.	SECTION No.	
P-18382-1	-	
S5927	S5927	

1. ALL DIMENSIONS ARE IN mm.
2. ROUND OFF ALL SHARP CORNERS WITH 0.40 mm.
3. TOLERANCES WILL BE AS PER IS:6477-1983, UNLESS OTHERWISE SPECIFIED

PARTY'S NAME	MIVIN ENGG. TECHNOLOGIES PVT. LTD., BANGALORE
PARTY'S DRAWING No.	E181100325
ALLOY & TEMPER	6082 T6
DESCRIPTION	PUMP BODY SECTION