

P-18373

S5936

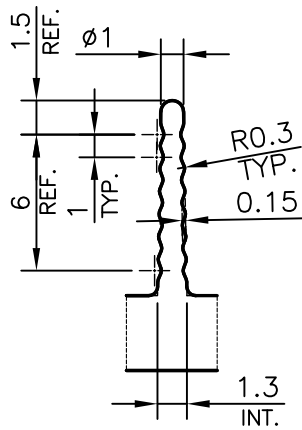

DETAIL OF "A"
SCALE 3:1

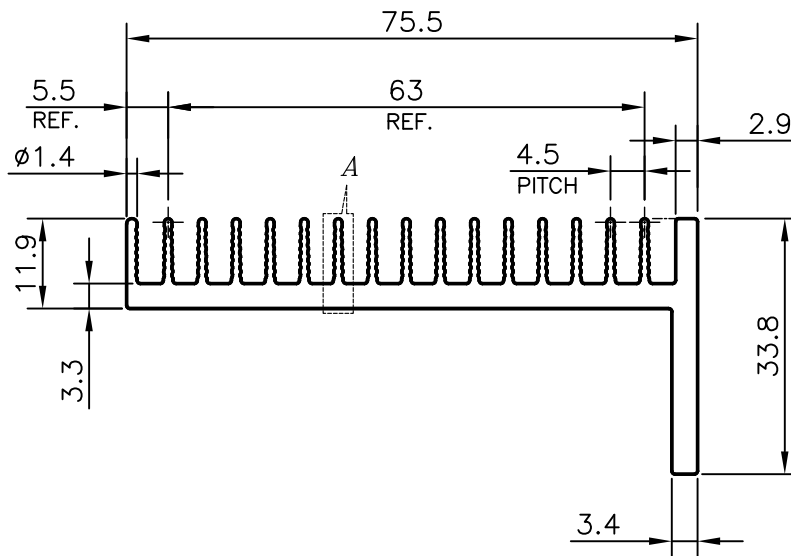

SYMBOL OF QUALITY
AN ISO 9001 COMPANY

JINDAL ALUMINIUM LTD.
BANGALORE-560073 (INDIA)

	NAME	DATE
DRAWN	PARVESH	03-07-2018
CHECKED		
APPROVED	B.NATARAJA	21-07-2018
SCALE		1:1
AREA mm ²		490.646
PERIMETER mm.		487.056
WEIGHT kg/m		1.325
DRAWING No.	SECTION No.	
P-18373	-	
S5936	S5936	

1. ALL DIMENSIONS ARE IN mm.
2. ROUND OFF ALL SHARP CORNERS WITH 0.4 mm.
3. TOLERANCES WILL BE AS PER IS:3965-1981 , UNLESS OTHERWISE SPECIFIED

PARTY'S NAME	D. GANESH ELECTRICAL UNIT 2, RAJKOT
PARTY'S DRAWING No.	AS PER SAMPLE
ALLOY & TEMPER	6063 T6
DESCRIPTION	HEAT SINK SECTION