

P-18474

S5938

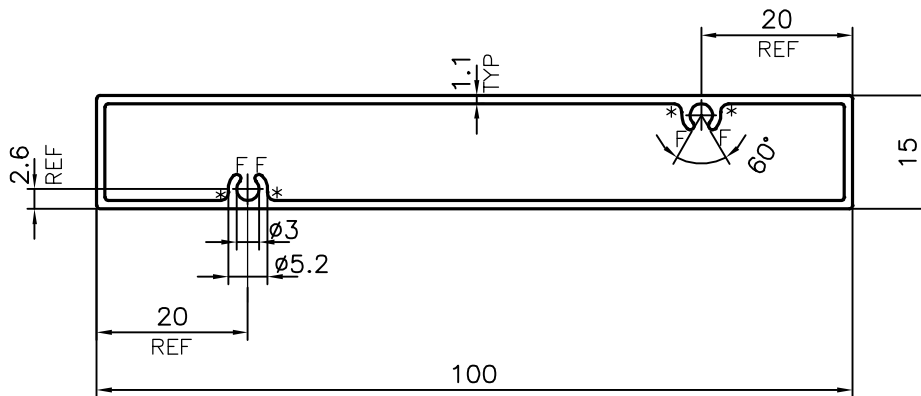

F = FULL RADIUS (4 PLACES)

\* = 1.0 RADIUS (4 PLACES)

TOLERANCES ON OVERALL WIDTHS & WIDTHS ACROSS FLATS OF BARS, & REGULAR SECTIONS

UPTO 6.40mm - ±0.20	UPTO 32.0mm - ±0.38	UPTO 120.0mm - ±0.85	UPTO 320.00mm - ±1.70
UPTO 10.0mm - ±0.23	UPTO 50.0mm - ±0.46	UPTO 160.0mm - ±1.02	
UPTO 12.0mm - ±0.25	UPTO 60.0mm - ±0.53	UPTO 200.0mm - ±1.14	
UPTO 16.0mm - ±0.28	UPTO 80.0mm - ±0.69	UPTO 250.0mm - ±1.40	
UPTO 25.0mm - ±0.30	UPTO 100.0mm - ±0.75	UPTO 300.0mm - ±1.65	

 SYMBOL OF QUALITY AN ISO 9001 COMPANY	<b>JINDAL ALUMINIUM LTD.</b> BANGALORE-560073 (INDIA)	DRAWN	J.P.KAUSHIK	DATE	20-07-2018
		CHECKED			
1. ALL DIMENSIONS ARE IN mm. 2. ROUND OFF ALL SHARP CORNERS WITH 0.40 mm. 3. TOLERANCES WILL BE AS PER IS:6477-1983 , UNLESS OTHERWISE SPECIFIED		APPROVED	B.NATARAJA	DATE	23-07-2018
		SCALE			1:1
PARTY'S NAME D F SOLUTIONS, BANGALORE		AREA	mm <sup>2</sup>		266.277
		PERIMETER	mm.		229.313
PARTY'S DRAWING No. AS PER DRAWING		WEIGHT	kg/m		0.719
		DRAWING No.		SECTION No.	
ALLOY & TEMPER 6063 T6		P-18474			-
		S5938			S5938
DESCRIPTION RECTANGULAR TUBE-MISC.					