

P-18670-1

S5979

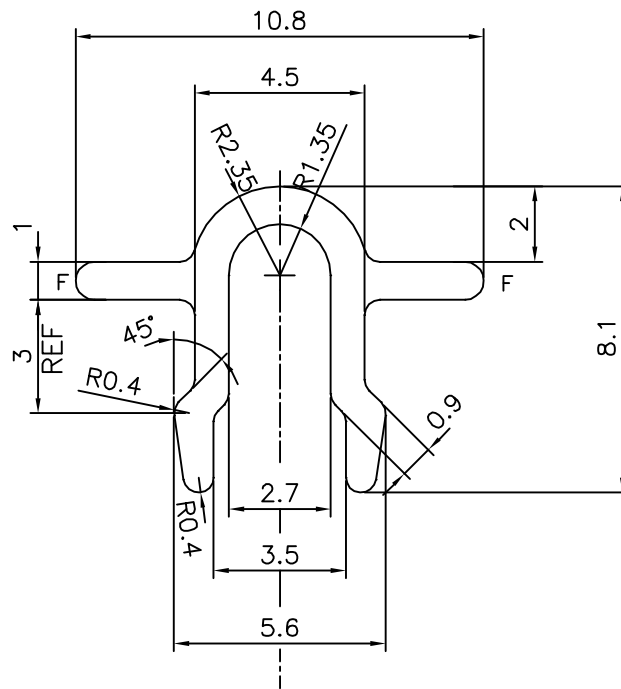

1:1



F = FULL RADIUS (2 PLACES)



SYMBOL OF QUALITY
AN ISO 9001 COMPANY

JINDAL ALUMINIUM LTD.
BANGALORE-560073 (INDIA)

	NAME	DATE
DRAWN	J.P.KAUSHIK	14-09-2018
CHECKED		
APPROVED	B.NATARAJA	18-09-2018
SCALE		5:1
AREA mm ²		22.543
PERIMETER mm.		47.267
WEIGHT kg/m		0.061
DRAWING No.	SECTION No.	
P-18670-1	-	
S5979	S5979	

1. ALL DIMENSIONS ARE IN mm.
2. ROUND OFF ALL SHARP CORNERS WITH 0.40 mm.
3. TOLERANCES WILL BE AS PER IS:3965-1981 , UNLESS OTHERWISE SPECIFIED

PARTY'S NAME	AKSHARA ENTERPRISES, BANGALORE
PARTY'S DRAWING No.	AS PER SAMPLE & REQUIREMENT
ALLOY & TEMPER	6063 T6
DESCRIPTION	MISC. SECTION