

P-18659-1

S5985

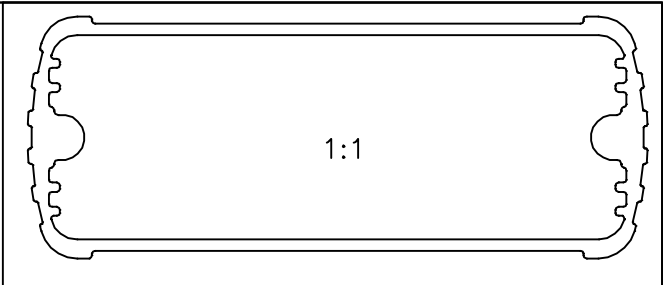

SECTION PROFILE IS SYMMETRICAL ABOUT CENTRE LINE

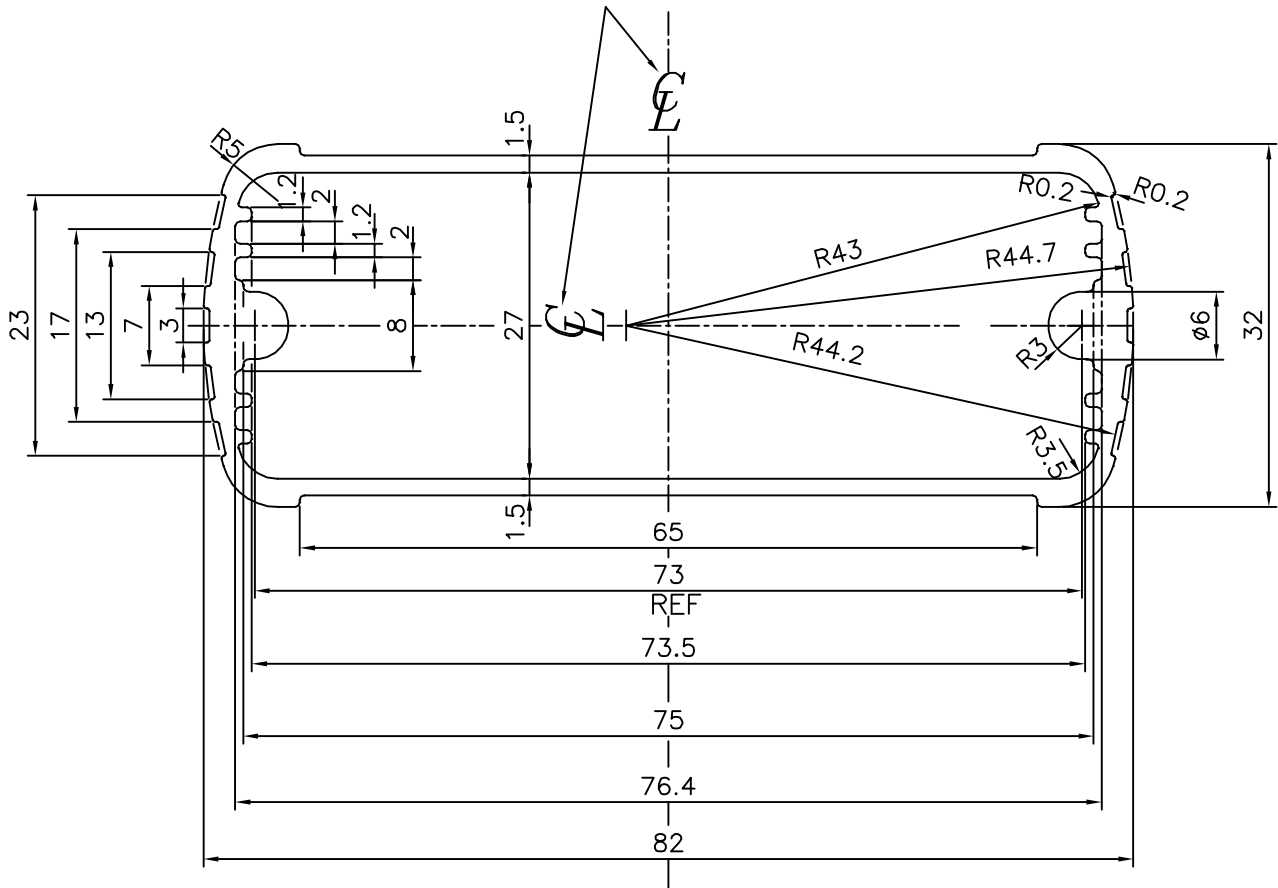

F = FULL RADIUS (4 PLACES)

TOLERANCES ON OVERALL WIDTHS & WIDTHS ACROSS FLATS OF BARS, & REGULAR SECTIONS

UPTO 6.40mm - ±0.20	UPTO 32.0mm - ±0.38	UPTO 120.0mm - ±0.85	UPTO 320.00mm - ±1.70
UPTO 10.0mm - ±0.23	UPTO 50.0mm - ±0.46	UPTO 160.0mm - ±1.02	
UPTO 12.0mm - ±0.25	UPTO 60.0mm - ±0.53	UPTO 200.0mm - ±1.14	
UPTO 16.0mm - ±0.28	UPTO 80.0mm - ±0.69	UPTO 250.0mm - ±1.40	
UPTO 25.0mm - ±0.30	UPTO 100.0mm - ±0.75	UPTO 300.0mm - ±1.65	



SYMBOL OF QUALITY
AN ISO 9001 COMPANY

JINDAL ALUMINIUM LTD.
BANGALORE-560073 (INDIA)

	NAME	DATE
DRAWN	J.P.KAUSHIK	22-09-2018
CHECKED		
APPROVED	B.NATARAJA	26-09-2018

1. ALL DIMENSIONS ARE IN mm.
2. ROUND OFF ALL SHARP CORNERS WITH 0.40 mm.
3. TOLERANCES WILL BE AS PER IS:6477-1983 , UNLESS OTHERWISE SPECIFIED

SCALE	1.5:1
AREA mm ²	422.049
PERIMETER mm.	222.642
WEIGHT kg/m	1.140

PARTY'S NAME	PRAGATHI SOLUTIONS, BANGALORE
PARTY'S DRAWING No.	PRAG-DRG-18-19-00-001
ALLOY & TEMPER	6063 T6
DESCRIPTION	MISC. TUBE

DRAWING No.	SECTION No.
P-18659-1	-
S5985	S5985