

P-18488-1

S5989

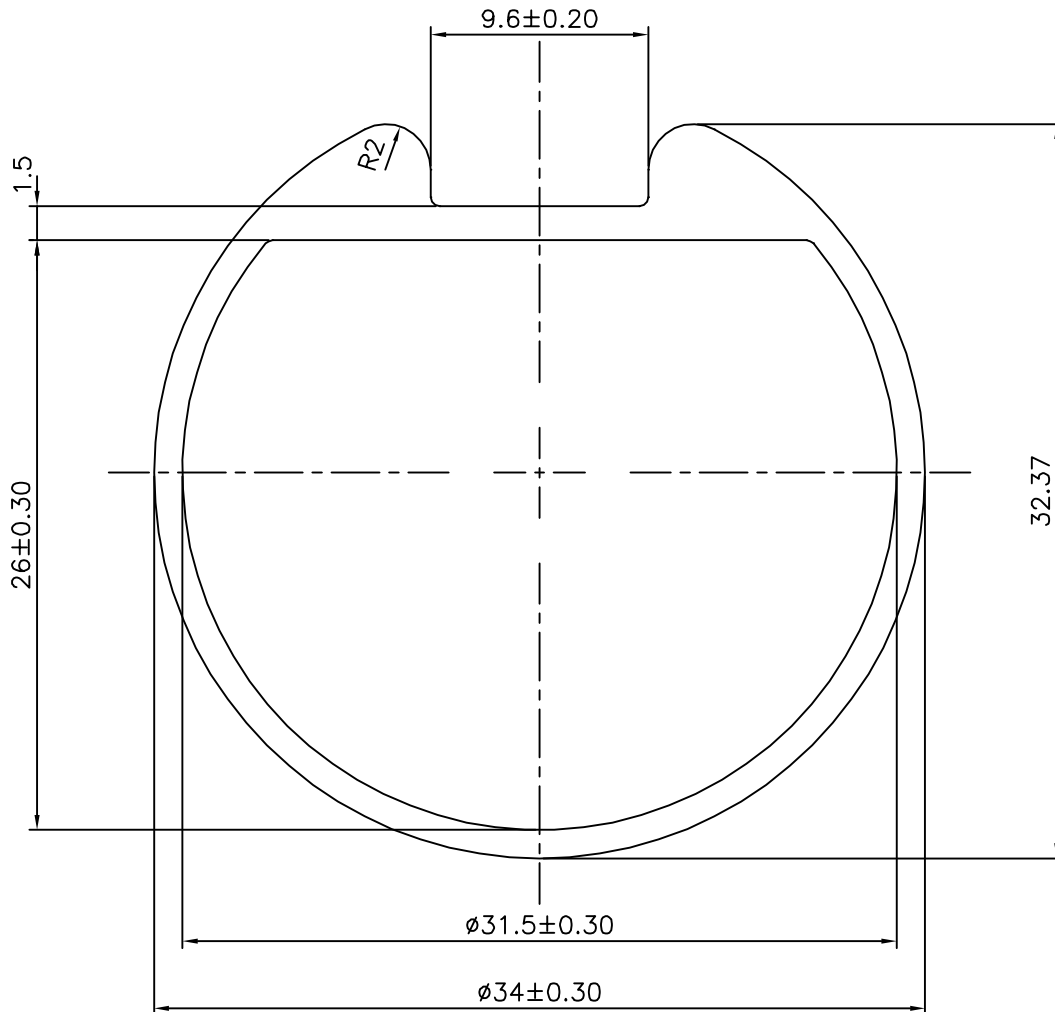
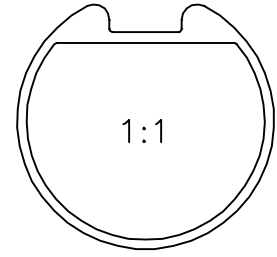

SYMBOL OF QUALITY
AN ISO 9001 COMPANY

JINDAL ALUMINIUM LTD.
BANGALORE-560073 (INDIA)

	NAME	DATE
DRAWN	J.P.KAUSHIK	28-09-2018
CHECKED		
APPROVED	B.NATARAJA	01-10-2018
SCALE		3:1
AREA mm ²		167.54
PERIMETER mm.		111.479
WEIGHT kg/m		0.452
DRAWING No.	SECTION No.	
P-18488-1	-	
S5989	S5989	

1. ALL DIMENSIONS ARE IN mm.
2. ROUND OFF ALL SHARP CORNERS WITH 0.40 mm.
3. TOLERANCES WILL BE AS PER IS:6477-1983 UNLESS OTHERWISE SPECIFIED

PARTY'S NAME	FALCON GARDEN TOOLS PVT. LTD., LUDHIANA
PARTY'S DRAWING No.	AS PER DRAWING
ALLOY & TEMPER	6063 T6
DESCRIPTION	ROUND TUBE-MISC.