

P-18135

S6003

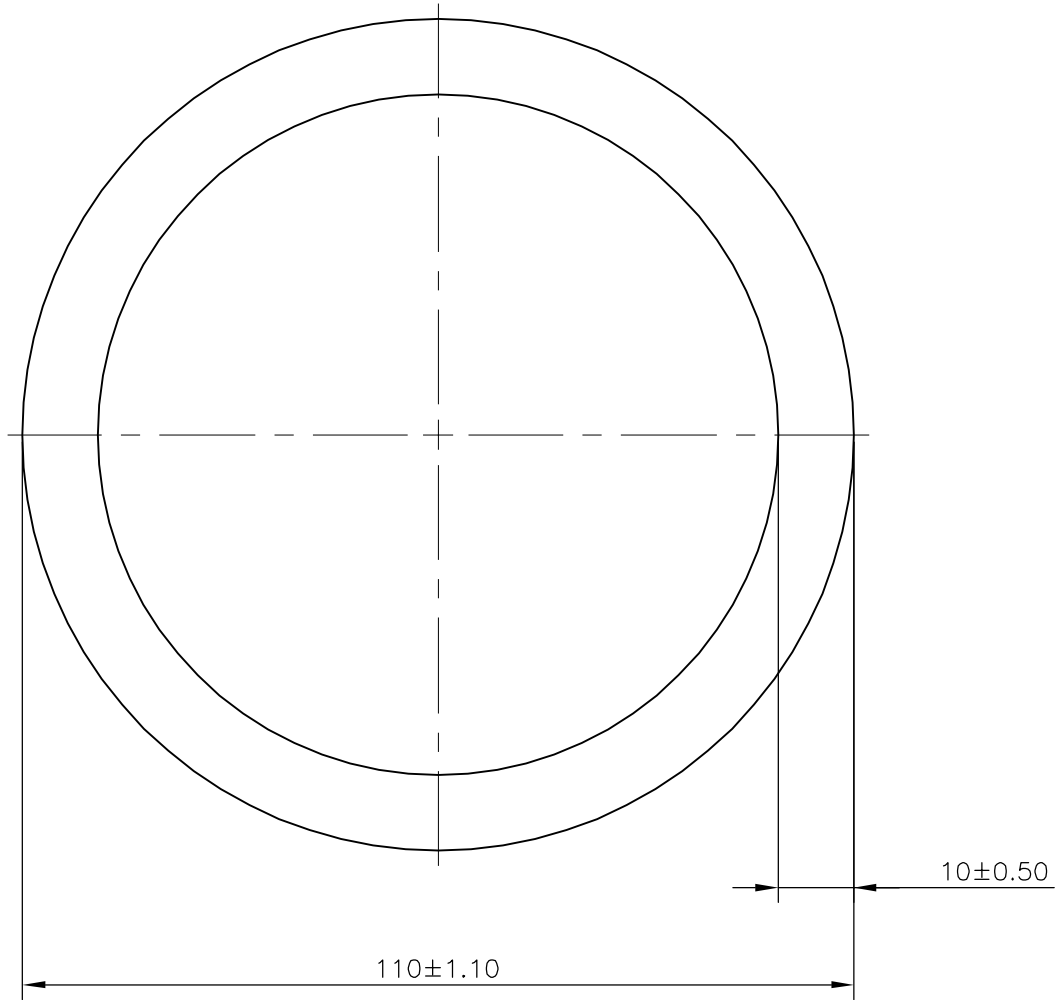

SYMBOL OF QUALITY  
AN ISO 9001 COMPANY

**JINDAL ALUMINIUM LTD.**  
BANGALORE-560073 (INDIA)

	NAME	DATE
DRAWN	J.P.KAUSHIK	19-04-2018
CHECKED		
APPROVED	B.NATARAJA	12-10-2018
SCALE		1:1
AREA mm <sup>2</sup>		3141.593
PERIMETER mm.		345.575
WEIGHT kg/m		8.482
DRAWING No.	SECTION No.	
P-18135	-	
S6003	S6003	

1. ALL DIMENSIONS ARE IN mm.
2. ROUND OFF ALL SHARP CORNERS WITH 0.40 mm.
3. TOLERANCES WILL BE AS PER IS:2673-2002 , UNLESS OTHERWISE SPECIFIED

PARTY'S NAME	RABWIN INDUSTRIES PVT. LTD., COIMBATORE
PARTY'S DRAWING No.	AS PER SPECIFICATION
ALLOY & TEMPER	6101B7
DESCRIPTION	ROUND TUBE