

P-18292

S6012

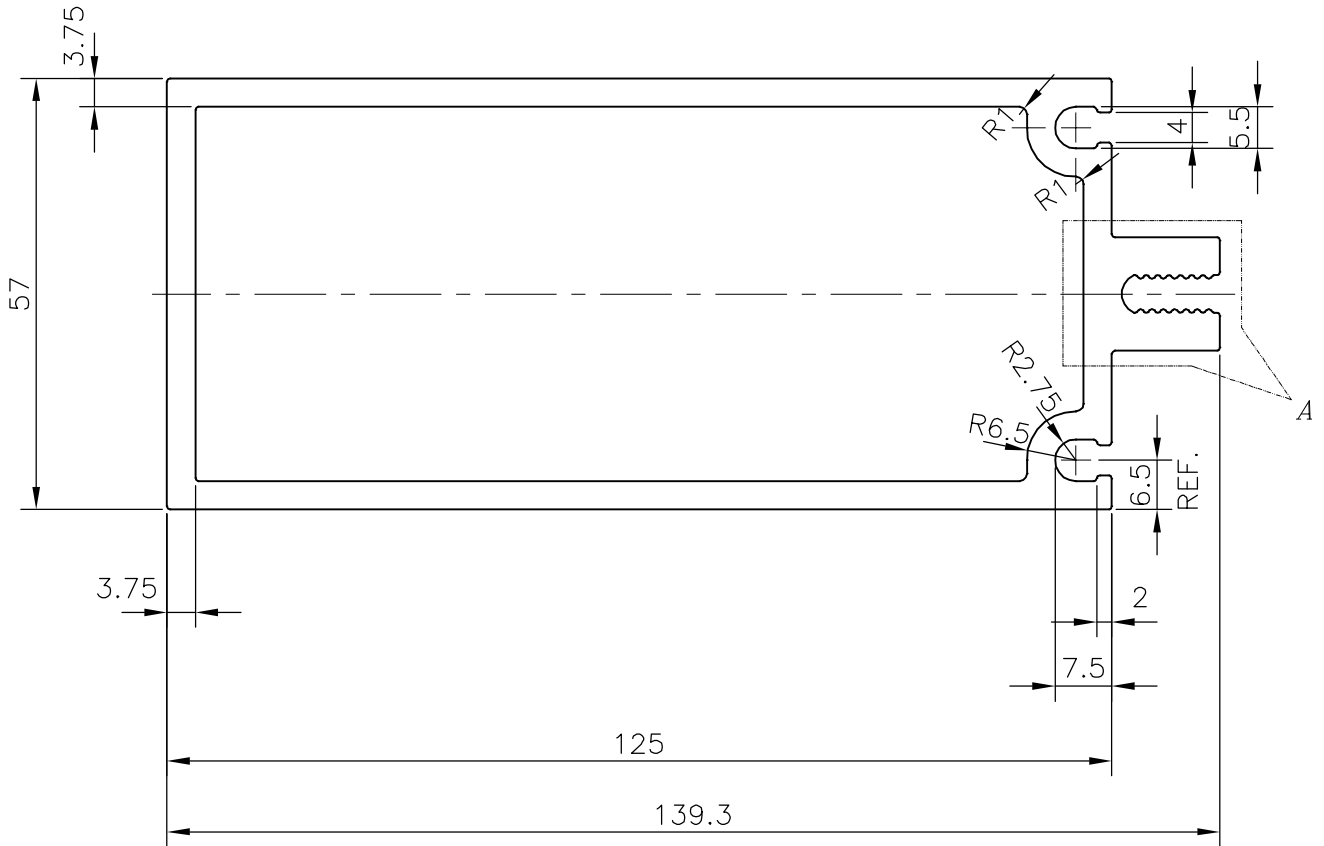
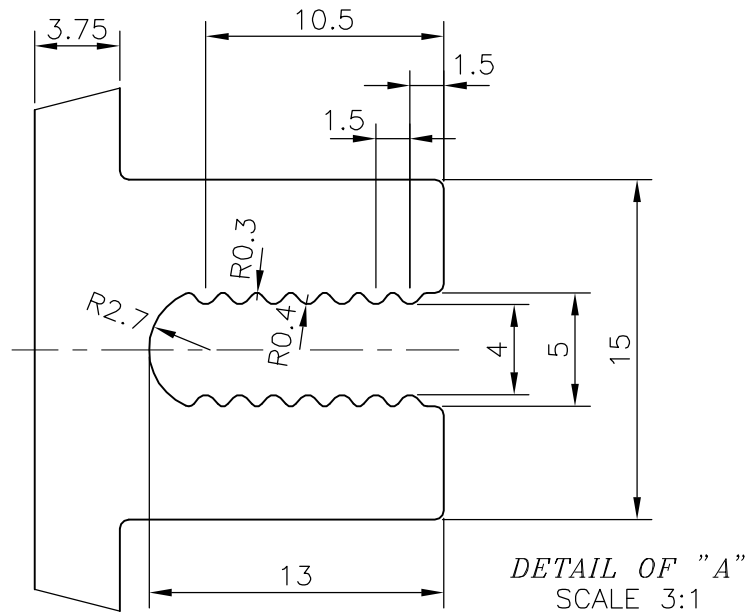

SYMBOL OF QUALITY  
AN ISO 9001 COMPANY

**JINDAL ALUMINIUM LTD.**  
BANGALORE-560073 (INDIA)

	NAME	DATE
DRAWN	J.P.KAUSHIK	04-06-2018
CHECKED		
APPROVED	B.NATARAJA	20-10-2018
SCALE		1:1
AREA mm <sup>2</sup>		1517.278
PERIMETER mm.		449.448
WEIGHT kg/m		4.097
DRAWING No.	SECTION No.	
P-18292	-	
S6012	S6012	

1. ALL DIMENSIONS ARE IN mm.
2. ROUND OFF ALL SHARP CORNERS WITH 0.40 mm.
3. TOLERANCES WILL BE AS PER IS:6477-1983 , UNLESS OTHERWISE SPECIFIED

PARTY'S NAME	FUTURE INTERIOR GROUP, LUCKNOW
PARTY'S DRAWING No.	MODIFIED OF 22714
ALLOY & TEMPER	6063 T6
DESCRIPTION	MULLION SECTION