

P-18801

S6024

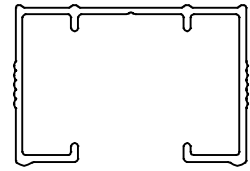

1:1

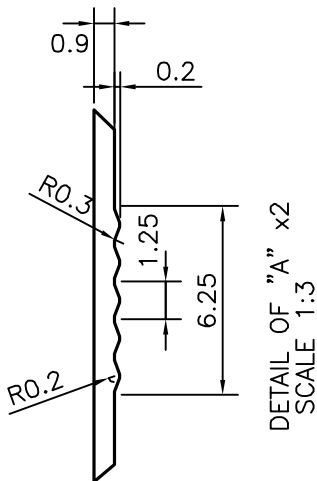
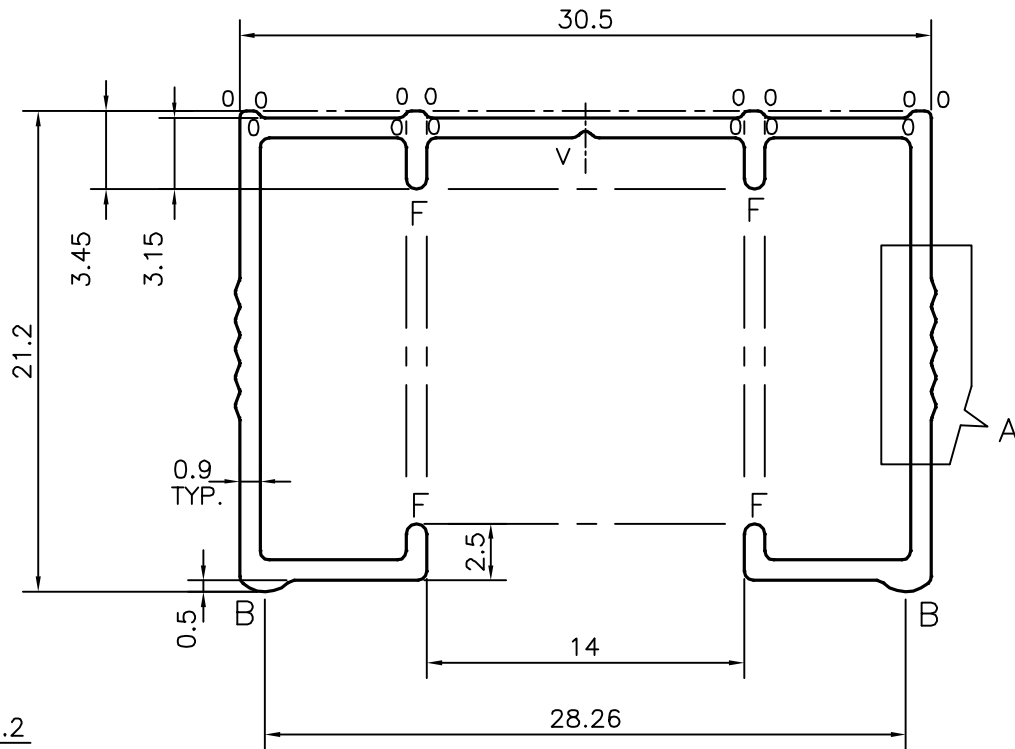

- V = "V" GROOVE 0.30x90° (1 PLACE)
- O = R0.3 (14 PLACES)
- F = FULL RADIUS (4 PLACES)
- B = R1.5 mm (2 PLACES)



SYMBOL OF QUALITY
AN ISO 9001 COMPANY

JINDAL ALUMINIUM LTD.
BANGALORE-560073 (INDIA)

	NAME	DATE
DRAWN	DARPAN	02-11-2018
CHECKED		
APPROVED	B.NATARAJA	03-11-2018
SCALE		3:1
AREA mm ²		86.274
PERIMETER mm.		184.367
WEIGHT kg/m		0.233
DRAWING No.	SECTION No.	
P-18801	-	
S6024	S6024	

1. ALL DIMENSIONS ARE IN mm.
2. ROUND OFF ALL SHARP CORNERS WITH 0.40 mm.
3. TOLERANCES WILL BE AS PER IS:3965-1981 , UNLESS OTHERWISE SPECIFIED

PARTY'S NAME	RAM FABRICATE, BANGLORE
PARTY'S DRAWING No.	AS PER SAMPLE
ALLOY & TEMPER	6063 T6
DESCRIPTION	MISC, SECTION