

P-18810-2

S6029

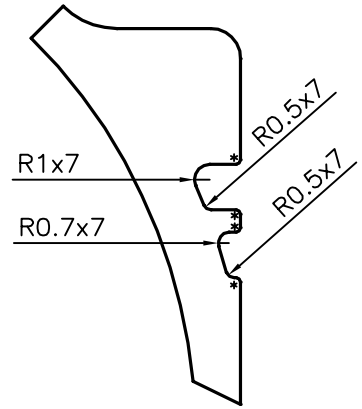

DETAIL OF "A"
SCALE 2:1

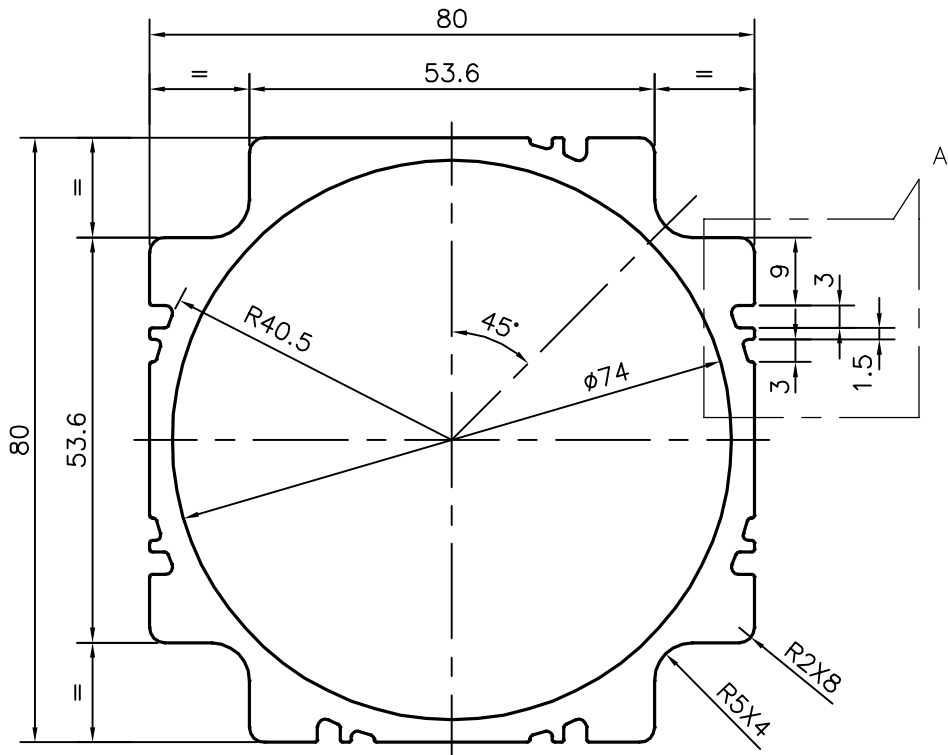

* = R0.3 mm (28 PLACES)



SYMBOL OF QUALITY
AN ISO 9001 COMPANY

JINDAL ALUMINIUM LTD.
BANGALORE-560073 (INDIA)

	NAME	DATE
DRAWN	DARPAN	14-11-2018
CHECKED		
APPROVED	B.NATARAJA	17-11-2018

1. ALL DIMENSIONS ARE IN mm.
2. ROUND OFF ALL SHARP CORNERS WITH 0.40 mm.
3. TOLERANCES WILL BE AS PER IS:6477-1983 , UNLESS OTHERWISE SPECIFIED

SCALE	1:1
AREA mm ²	1333.699
PERIMETER mm.	349.738
WEIGHT kg/m	3.601

PARTY'S NAME	PRAGATI AUTOMATION PVT LTD, BANGALORE.	DRAWING No.	P-18810-2	SECTION No.	-
PARTY'S DRAWING No.	CS240201-EXT (REV-02)		S6029		S6029
ALLOY & TEMPER	6060 T6				
DESCRIPTION	MOTOR HOUSING SECTION				