

P-18896

S6071

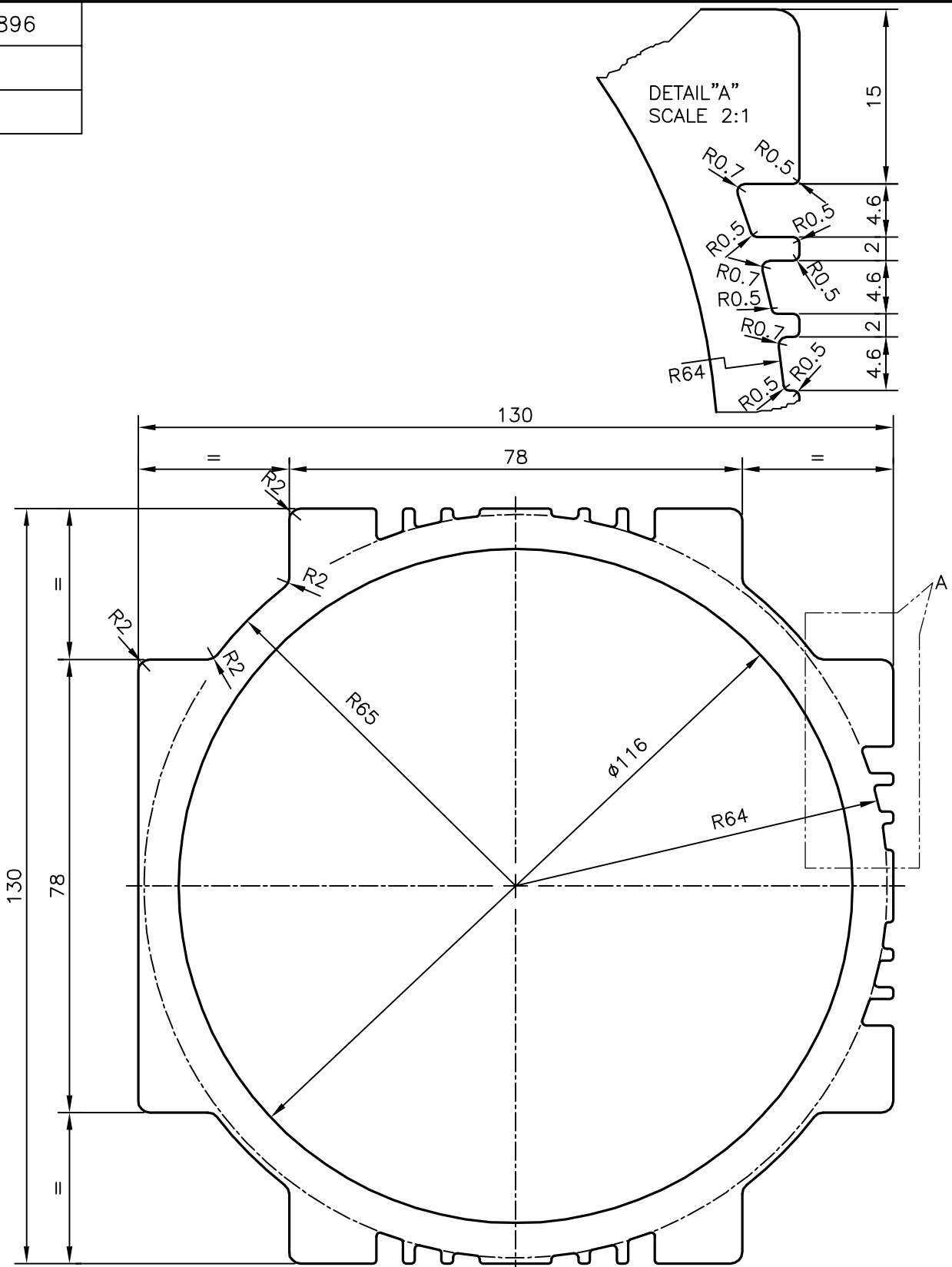

SYMBOL OF QUALITY
AN ISO 9001 COMPANY

JINDAL ALUMINIUM LTD.
BANGALORE-560073 (INDIA)

	NAME	DATE
DRAWN	J.P.KAUSHIK	20-11-2018
CHECKED		
APPROVED	B,NATARAJA	11-12-2018
SCALE		1:1
AREA mm ²		3739.961
PERIMETER mm.		576.019
WEIGHT kg/m		10.098
DRAWING No.	SECTION No.	
P-18896	-	
S6071	S6071	

1. ALL DIMENSIONS ARE IN mm.
2. ROUND OFF ALL SHARP CORNERS WITH 0.40 mm.
3. TOLERANCES WILL BE AS PER IS:6477-1983 , UNLESS OTHERWISE SPECIFIED

PARTY'S NAME	PRAGATI AUTOMATION PVT. LTD., BANGALORE
PARTY'S DRAWING No.	CS740102-EXT
ALLOY & TEMPER	6060 T6
DESCRIPTION	PUMP BODY SECTION