

P-18901

S6074

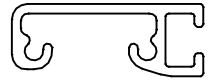

1:1

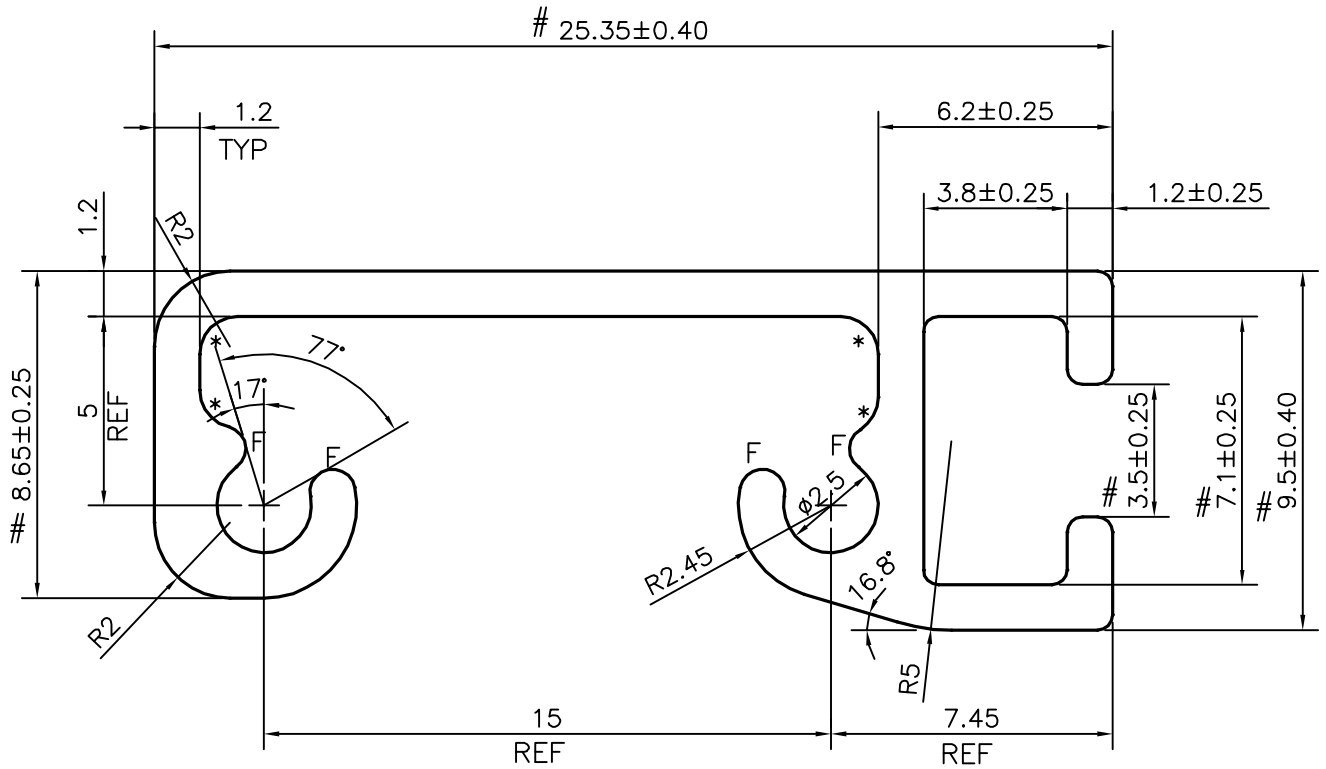

= CRITICAL DIMENSIONS
 * = 1.0 RADIUS (4 PLACES)
 F = FULL RADIUS (4 PLACES)



SYMBOL OF QUALITY
 AN ISO 9001 COMPANY

JINDAL ALUMINIUM LTD.
 BANGALORE-560073 (INDIA)

	NAME	DATE
DRAWN	J.P.KAUSHIK	23-11-2018
CHECKED		
APPROVED	B.NATARAJA	13-12-2018

1. ALL DIMENSIONS ARE IN mm.
2. ROUND OFF ALL SHARP CORNERS WITH 0.40 mm.
3. TOLERANCES WILL BE AS PER IS:3965-1981 , UNLESS OTHERWISE SPECIFIED

SCALE	5:1
AREA mm ²	75.129
PERIMETER mm.	116.916
WEIGHT kg/m	0.203

PARTY'S NAME	JAYANITA EXPORTS PVT. LTD., GREATER NOIDA
PARTY'S DRAWING No.	AS PER DRAWING-01
ALLOY & TEMPER	6063 T6
DESCRIPTION	TOP TRACK FOR ZEBRA BLIND

DRAWING No.	SECTION No.
P-18901	-
S6074	S6074