

P-18924-1

S6082

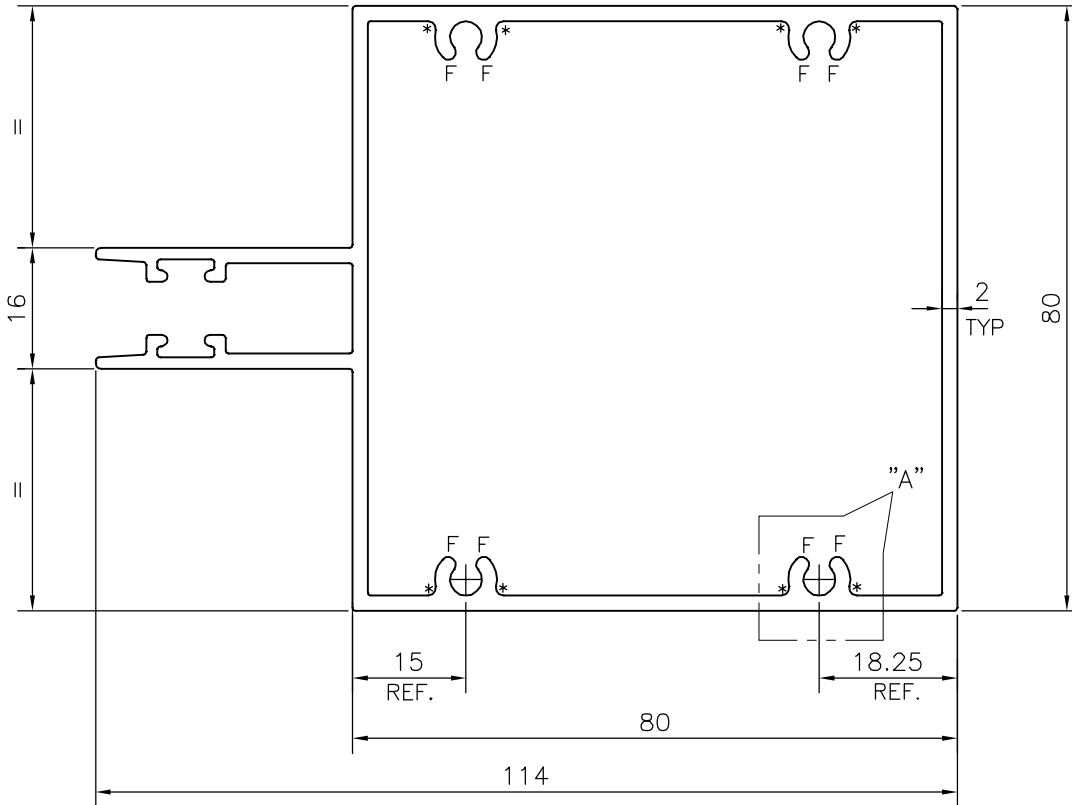
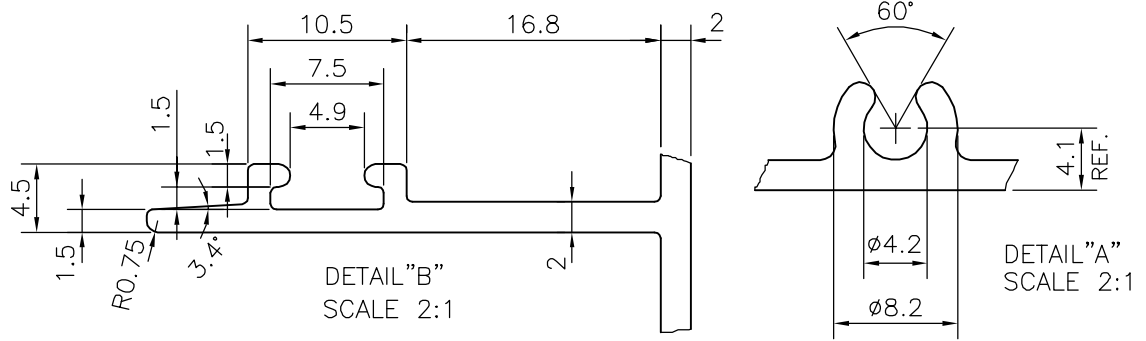

NOTE:-

DIMENSION CHANGED FROM 18 mm TO 16 mm  
AS PER PARTY'S E-MAIL DATED 24/12/2018

\*= RADIUS 1.0 (8 PLACES )

F= FULL RADIUS (8 PLACES )

TOLERANCES ON OVERALL DIMENSIONS OF HOLLOW SECTIONS

UPTO 20.0mm - ±0.30	UPTO 80.0mm - ±0.70	UPTO 180.0mm - ±1.27	1. STRAIGHTNESS=1.7mm/M 2. TWIST=1.7mm/M 3. ANGULARITY= ±2° 4. FLATNESS =0.006xWIDTH
UPTO 30.0mm - ±0.38	UPTO 100.0mm - ±0.80	UPTO 200.0mm - ±1.40	
UPTO 40.0mm - ±0.45	UPTO 120.0mm - ±0.90	UPTO 225.0mm - ±1.52	
UPTO 50.0mm - ±0.52	UPTO 140.0mm - ±1.00		
UPTO 60.0mm - ±0.60	UPTO 160.0mm - ±1.14		



SYMBOL OF QUALITY  
AN ISO 9001 COMPANY

**JINDAL ALUMINIUM LTD.**  
BANGALORE-560073 (INDIA)

	NAME	DATE
DRAWN	J.P.KAUSHIK	24-12-2018
CHECKED		
APPROVED	B,NATARAJA	26-12-2018

1. ALL DIMENSIONS ARE IN mm.
2. ROUND OFF ALL SHARP CORNERS WITH 0.40 mm.
3. TOLERANCES WILL BE AS PER IS:6477-1983 , UNLESS OTHERWISE SPECIFIED

SCALE	1:1
AREA mm <sup>2</sup>	859.818
PERIMETER mm.	480.034
WEIGHT kg/m	2.322
DRAWING No.	SECTION No.
P-18924-1	-
S6082	S6082

PARTY'S NAME	PSP PROJECTS LTD., SURAT
PARTY'S DRAWING No.	FCD: AL-1005
ALLOY & TEMPER	6063 T6
DESCRIPTION	CURTAIN WALL TRANSOM SECTION