

P-19028-1

S6112

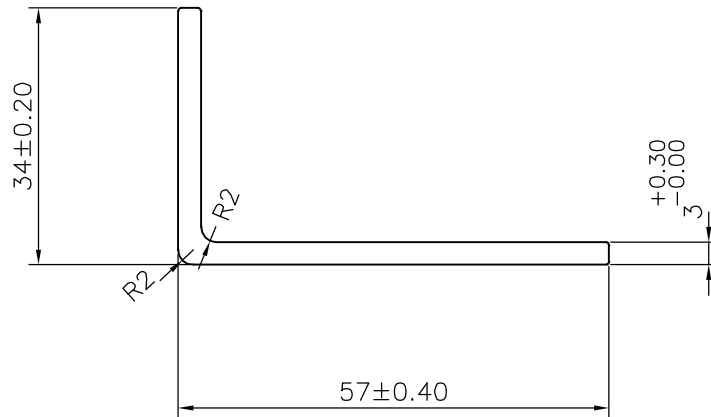

SYMBOL OF QUALITY
AN ISO 9001 COMPANY

JINDAL ALUMINIUM LTD.
BANGALORE-560073 (INDIA)

	NAME	DATE
DRAWN	J.P.KAUSHIK	18-01-2019
CHECKED		
APPROVED	B.NATARAJ	28-01-2019
SCALE	1:1	
AREA mm ²	263.863	
PERIMETER mm.	179.596	
WEIGHT kg/m	0.712	
DRAWING No.	SECTION No.	
P-19028-1	-	
S6112	S6112	

1. ALL DIMENSIONS ARE IN mm.
2. ROUND OFF ALL SHARP CORNERS WITH 0.40 mm.
3. TOLERANCES WILL BE AS PER IS:3965-1981, UNLESS OTHERWISE SPECIFIED

PARTY'S NAME	ELECTRONIC CORPORATION OF INDIA LTD., HYDERABAD
PARTY'S DRAWING No.	FB-6954-A4 REV. R2 2 OF 3
ALLOY & TEMPER	64430 WP
DESCRIPTION	UNEQUAL ANGLE-MISC.