

P-19092

S6137

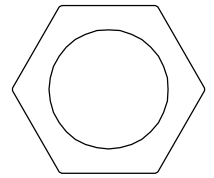

1:1

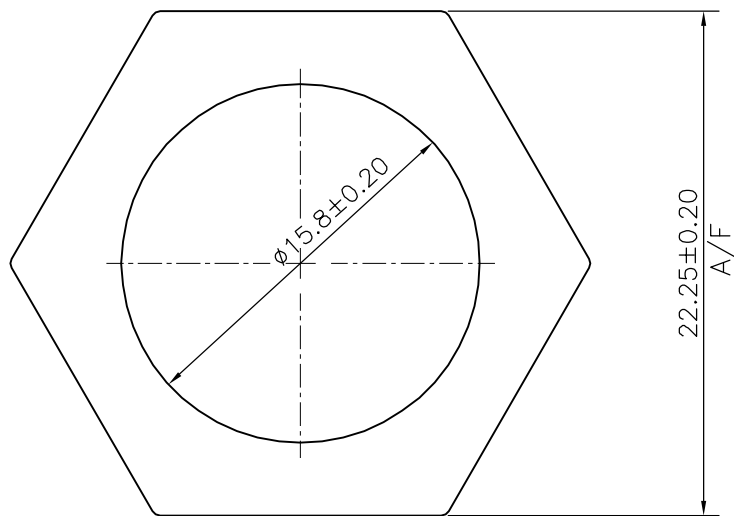

TOLERANCES ON OVERALL DIMENSIONS OF HOLLOW SECTIONS

UPTO 20.0mm - ± 0.30
 UPTO 30.0mm - ± 0.38
 UPTO 40.0mm - ± 0.45
 UPTO 50.0mm - ± 0.52
 UPTO 60.0mm - ± 0.60

UPTO 80.0mm - ± 0.70
 UPTO 100.0mm - ± 0.80
 UPTO 120.0mm - ± 0.90
 UPTO 140.0mm - ± 1.00
 UPTO 160.0mm - ± 1.14

UPTO 180.0mm - ± 1.27
 UPTO 200.0mm - ± 1.40
 UPTO 225.0mm - ± 1.52

1. STRAIGHTNESS=1.7mm/M
 2. TWIST=1.7mm/M
 3. ANGULARITY= $\pm 2^\circ$
 4. FLATNESS =0.006xWIDTH



SYMBOL OF QUALITY
 AN ISO 9001 COMPANY

JINDAL ALUMINIUM LTD.
 BANGALORE-560073 (INDIA)

	NAME	DATE
DRAWN	J.P.KAUSHIK	02-02-2019
CHECKED		
APPROVED	B.NATARAJA	09-02-2019

- ALL DIMENSIONS ARE IN mm.
- ROUND OFF ALL SHARP CORNERS WITH 0.40 mm.
- TOLERANCES WILL BE AS PER IS:6477-1983 , UNLESS OTHERWISE SPECIFIED

SCALE	3:1
AREA mm ²	232.618
PERIMETER mm.	76.818
WEIGHT kg/m	0.628

PARTY'S NAME	TOPFLITE COMPONENTS PVT. LTD., MYSOURE
PARTY'S DRAWING No.	TF-MSKI-354A-ROD
ALLOY & TEMPER	6061 T6
DESCRIPTION	HEXAGONAL TUBE

DRAWING No.	SECTION No.
P-19092	-
S6137	S6137