

P-19159

S6146

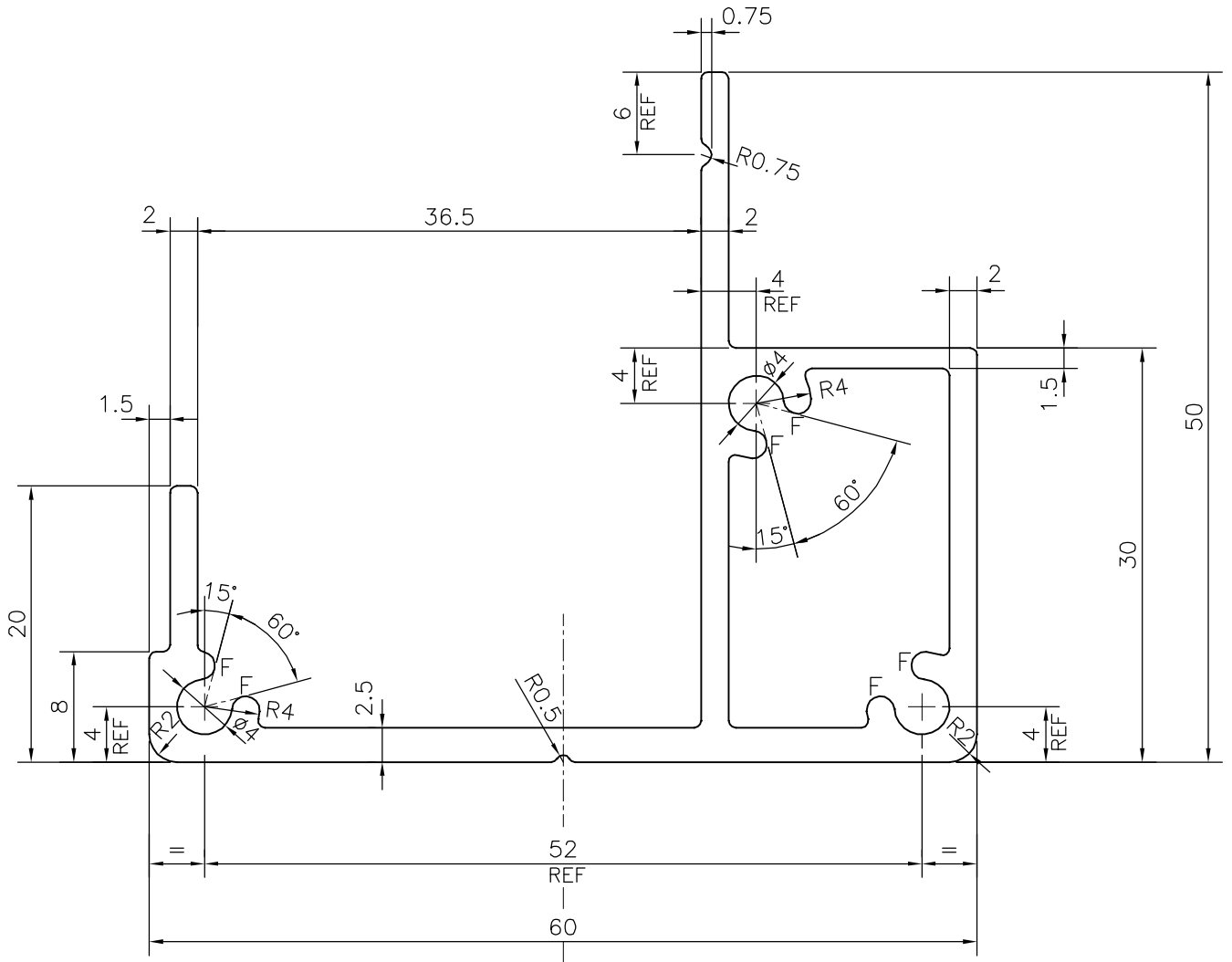

UNSPECIFIED RADIUS 0.5 mm  
F = FULL RADIUS(6 PLACES)

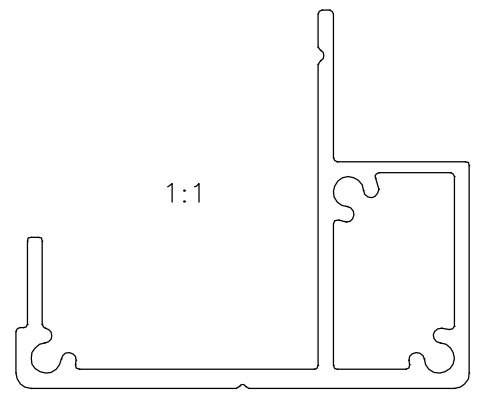

SYMBOL OF QUALITY  
AN ISO 9001 COMPANY

**JINDAL ALUMINIUM LTD.**  
BANGALORE-560073 (INDIA)

	NAME	DATE
DRAWN	J.P.KAUSHIK	19-02-2019
CHECKED		
APPROVED	B.NATARAJA	23-02-2019
SCALE		2:1
AREA mm <sup>2</sup>		390.201
PERIMETER mm.		258.811
WEIGHT kg/m		1.054
DRAWING No.	SECTION No.	
P-19159	-	
S6146	S6146	

1. ALL DIMENSIONS ARE IN mm.
2. ROUND OFF ALL SHARP CORNERS WITH 0.40 mm.
3. TOLERANCES WILL BE AS PER IS:6477-1983 , UNLESS OTHERWISE SPECIFIED

PARTY'S NAME	FENEX LUMINUS PVT. LTD., BANGALORE
PARTY'S DRAWING No.	AS PER DRAWING
ALLOY & TEMPER	6063 T6
DESCRIPTION	MISC. SECTION