

P-19189

S6150

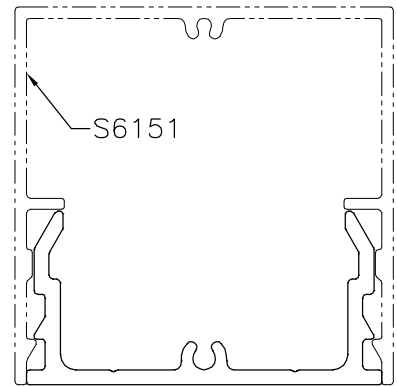

DETAIL OF "A"  
SCALE 3:1

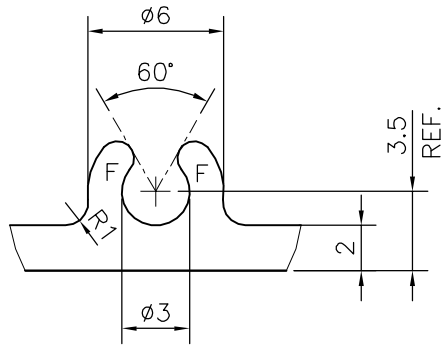
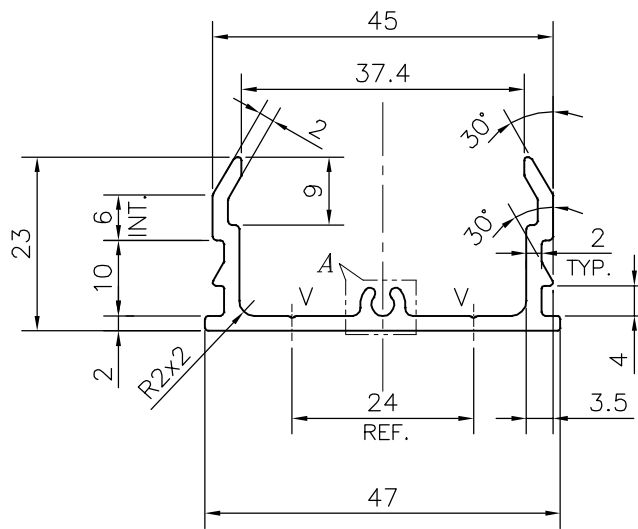

F = FULL RADIUS (2 PLACES)

V = VEE GROOVE  $0.30 \times 90^\circ$  (2 PLACES)



SYMBOL OF QUALITY  
AN ISO 9001 COMPANY

**JINDAL ALUMINIUM LTD.**  
BANGALORE-560073 (INDIA)

	NAME	DATE
DRAWN	J.P.KAUSHIK	22-02-2019
CHECKED		
APPROVED	B.NATARAJA	02-03-2019
SCALE		1:1
AREA mm <sup>2</sup>		202.917
PERIMETER mm.		198.775
WEIGHT kg/m		0.548
DRAWING No.	SECTION No.	
P-19189	-	
S6150	S6150	

1. ALL DIMENSIONS ARE IN mm.
2. ROUND OFF ALL SHARP CORNERS WITH 0.40 mm.
3. TOLERANCES WILL BE AS PER IS:3965-1981 , UNLESS OTHERWISE SPECIFIED

PARTY'S NAME	CEIFLO TECHNOLOGIES OVT LTD.,BANGALORE
PARTY'S DRAWING No.	AS PER DRAWING
ALLOY & TEMPER	6063 T6
DESCRIPTION	ARCHITECTURAL SECTION