

P-19215

S6156

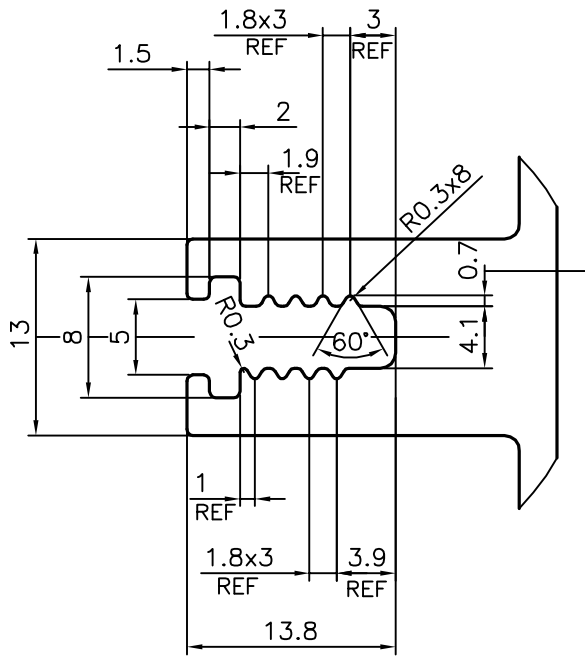

SCALE 2:1  
DETAIL OF "A"

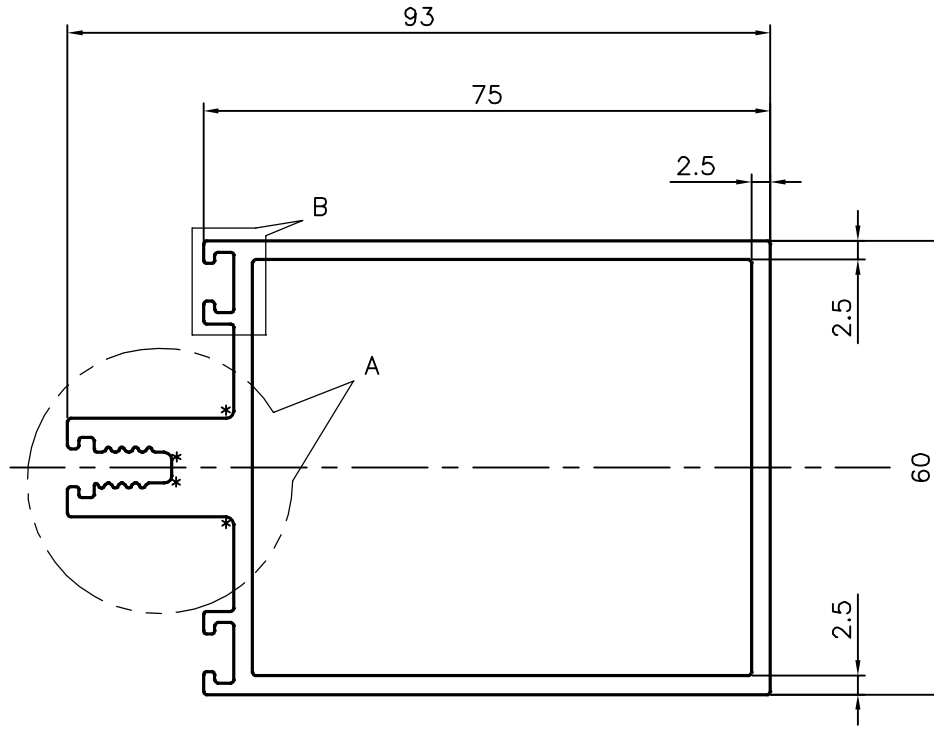
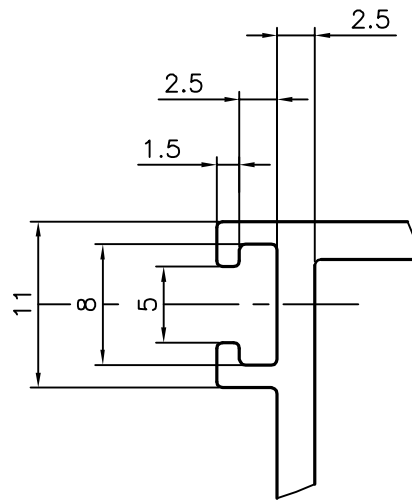

SCALE 2:1  
DETAIL OF "B"

\* = RADIUS 1.0 (4 PLACES)



SYMBOL OF QUALITY  
AN ISO 9002 COMPANY

**JINDAL ALUMINIUM LTD.**  
BANGALORE-560073 (INDIA)

|                      | NAME        | DATE       |
|----------------------|-------------|------------|
| DRAWN                | DARPAN      | 26-02-2019 |
| CHECKED              |             |            |
| APPROVED             | B.NATARAJA  | 02-03-2019 |
| SCALE                |             | 1:1        |
| AREA mm <sup>2</sup> |             | 879.764    |
| PERIMETER mm.        |             | 381.046    |
| WEIGHT kg/m          |             | 2.375      |
| DRAWING No.          | SECTION No. |            |
| P-19215              | -           |            |
| S6156                | S6156       |            |
|                      |             |            |
|                      |             |            |

1. ALL DIMENSIONS ARE IN mm.
2. ROUND OFF ALL SHARP CORNERS WITH 0.40 mm.
3. TOLERANCES WILL BE AS PER IS:6477-1983 UNLESS OTHERWISE SPECIFIED

|                     |                      |
|---------------------|----------------------|
| PARTY'S NAME        | GLAZIERS FACADE,PUNE |
| PARTY'S DRAWING No. | AS PER DRAWING       |
| ALLOY & TEMPER      | 6063 T6              |
| DESCRIPTION         | CURTAIN WALL SECTION |