

P-19132

S6160

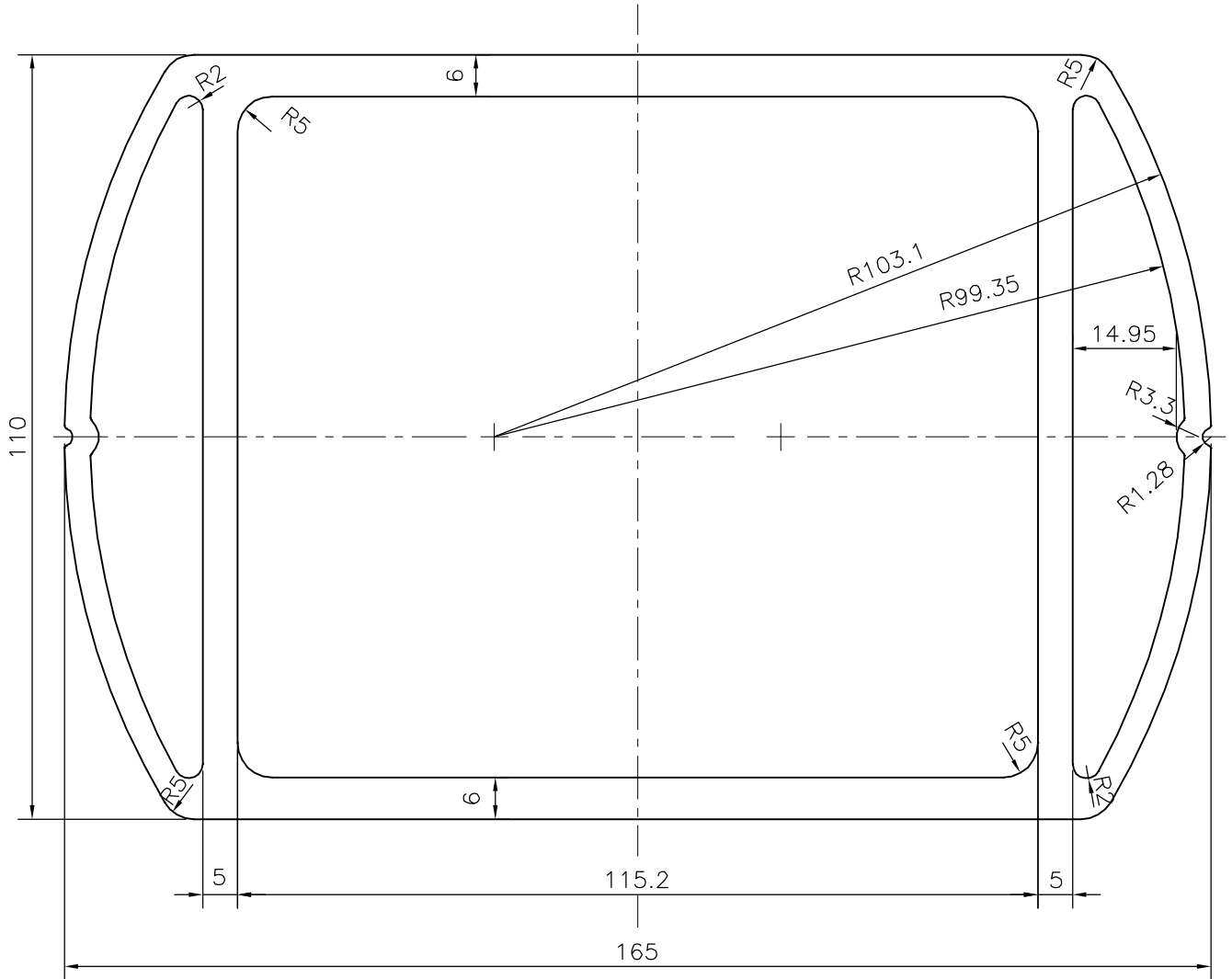

SYMBOL OF QUALITY
AN ISO 9001 COMPANY

JINDAL ALUMINIUM LTD.
BANGALORE-560073 (INDIA)

	NAME	DATE
DRAWN	J.P.KAUSHIK	11-02-2019
CHECKED		
APPROVED	B.NATARAJA	04-03-2019
SCALE		1:1
AREA mm ²		3412.013
PERIMETER mm.		498.598
WEIGHT kg/m		9.212
DRAWING No.	SECTION No.	
P-19132	-	
S6160	S6160	

1. ALL DIMENSIONS ARE IN mm.
2. ROUND OFF ALL SHARP CORNERS WITH 0.40 mm.
3. TOLERANCES WILL BE AS PER IS:6477-1983 , UNLESS OTHERWISE SPECIFIED

PARTY'S NAME	MEDIRAIL SYSTEMS, PUNE
PARTY'S DRAWING No.	AS PER DRAWING
ALLOY & TEMPER	6063 T6
DESCRIPTION	MEDICAL EQUIPMENT SECTION