

P-19228

S6166

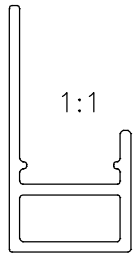

1:1

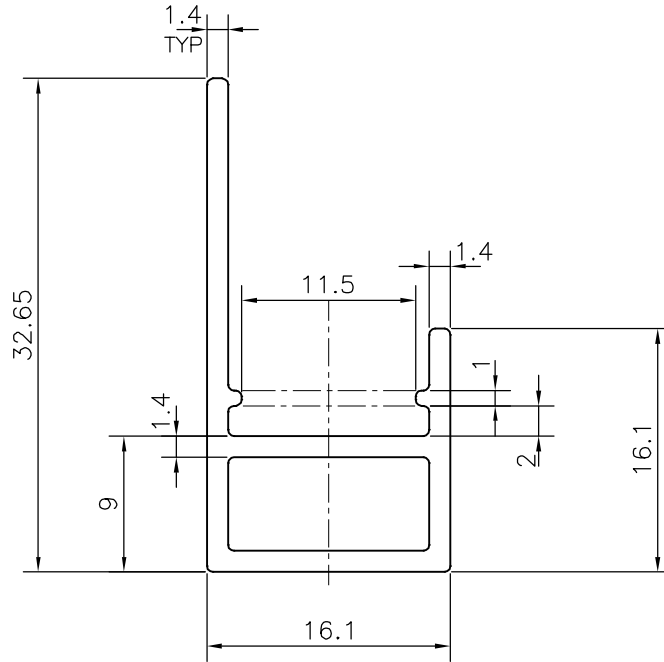

SYMBOL OF QUALITY
AN ISO 9001 COMPANY

JINDAL ALUMINIUM LTD.
BANGALORE-560073 (INDIA)

	NAME	DATE
DRAWN	J.P.KAUSHIK	04-03-2019
CHECKED		
APPROVED	B.NATARAJA	08-03-2019
SCALE		2:1
AREA mm ²		107.29
PERIMETER mm.		112.553
WEIGHT kg/m		0.290
DRAWING No.	SECTION No.	
P-19228	-	
S6166	S6166	

1. ALL DIMENSIONS ARE IN mm.
2. ROUND OFF ALL SHARP CORNERS WITH 0.40 mm.
3. TOLERANCES WILL BE AS PER IS:6477-1983 , UNLESS OTHERWISE SPECIFIED

PARTY'S NAME	PASOLITE ELECTRICALS PVT. LTD., BANGALORE
PARTY'S DRAWING No.	AS PER SAMPLE
ALLOY & TEMPER	6063 T6
DESCRIPTION	MISC. SECTION