

P-19163

S6169

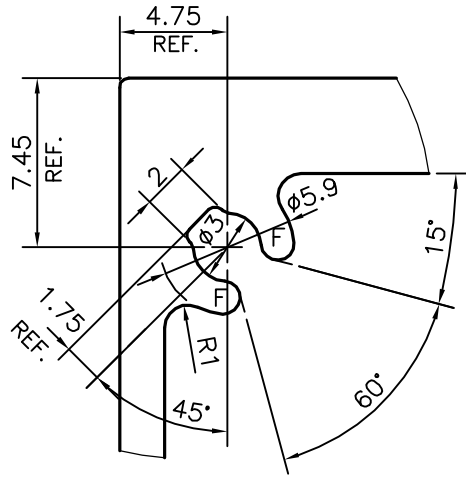

DETAIL OF "A"
SCALE 3:1

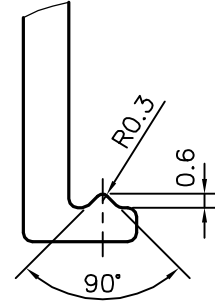

DETAIL OF "B"
SCALE 3:1

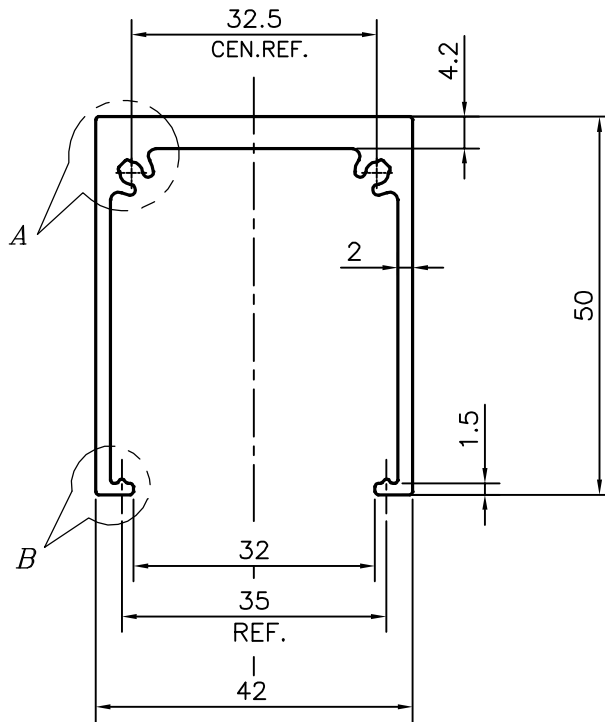

F = FULL RADIUS (4 PLACES)



SYMBOL OF QUALITY
AN ISO 9001 COMPANY

JINDAL ALUMINIUM LTD.
BANGALORE-560073 (INDIA)

| | NAME | DATE |
|----------------------|-------------|------------|
| DRAWN | DARPAN | 19-02-2019 |
| CHECKED | | |
| APPROVED | B.NATARAJA | 11-03-2019 |
| SCALE | | 1:1 |
| AREA mm ² | | 409.871 |
| PERIMETER mm. | | 299.271 |
| WEIGHT kg/m | | 1.107 |
| DRAWING No. | SECTION No. | |
| P-19163 | - | |
| S6169 | S6169 | |
| | | |
| | | |

1. ALL DIMENSIONS ARE IN mm.
2. ROUND OFF ALL SHARP CORNERS WITH 0.40 mm.
3. TOLERANCES WILL BE AS PER IS:3965-1981 , UNLESS OTHERWISE SPECIFIED

| | |
|---------------------|------------------------|
| PARTY'S NAME | AMMYS GLAZING,MUMBAI |
| PARTY'S DRAWING No. | AS PER AUTOCAD DRAWING |
| ALLOY & TEMPER | 6063 T6 |
| DESCRIPTION | CHANNEL, MISC. |