

P-19164

S6170

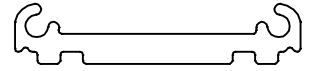

SCALE: - 1:1

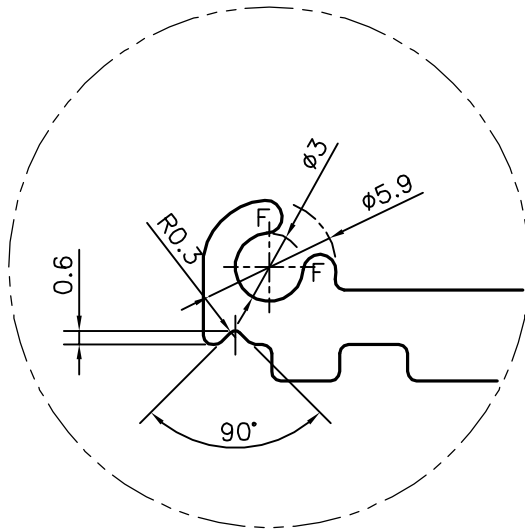

DETAIL OF "A"
SCALE 3:1

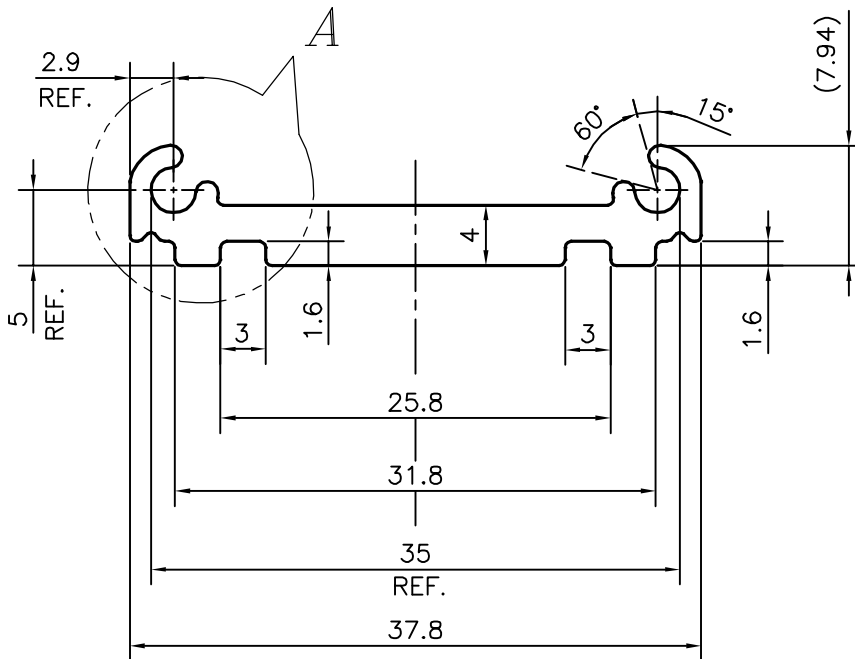

F = FULL RADIUS (4 PLACES)



SYMBOL OF QUALITY
AN ISO 9001 COMPANY

JINDAL ALUMINIUM LTD.
BANGALORE-560073 (INDIA)

	NAME	DATE
DRAWN	DARPAN	19-02-2019
CHECKED		
APPROVED	B.NATARAJA	11-03-2019
SCALE		2:1
AREA mm ²		148.037
PERIMETER mm.		111.803
WEIGHT kg/m		0.400
DRAWING No.	SECTION No.	
P-19164	-	
S6170	S6170	

1. ALL DIMENSIONS ARE IN mm.
2. ROUND OFF ALL SHARP CORNERS WITH 0.40 mm.
3. TOLERANCES WILL BE AS PER IS:3965-1981 , UNLESS OTHERWISE SPECIFIED

PARTY'S NAME	AMMYS GLAZING, MUMBAI
PARTY'S DRAWING No.	AS PER AUTOCAD DRAWING
ALLOY & TEMPER	6063 T6
DESCRIPTION	MISC. SECTION