

P-19168-2

S6173

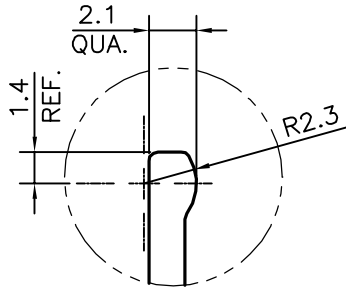

DETAIL OF "A"  
SCALE 3:1

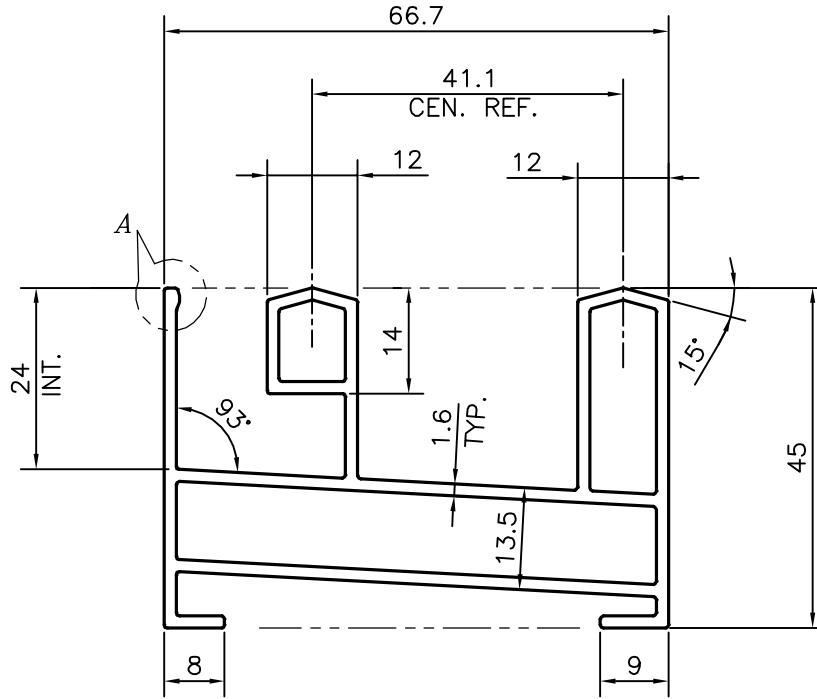

SYMBOL OF QUALITY  
AN ISO 9001 COMPANY

**JINDAL ALUMINIUM LTD.**  
BANGALORE-560073 (INDIA)

	NAME	DATE
DRAWN	DARPAN	07-03-2019
CHECKED		
APPROVED	B.NATARAJA	11-03-2019
SCALE		1:1
AREA mm <sup>2</sup>		511.098
PERIMETER mm.		376.185
WEIGHT kg/m		1.38
DRAWING No.	SECTION No.	
P-19168-2	-	
S6173	S6173	

1. ALL DIMENSIONS ARE IN mm.
2. ROUND OFF ALL SHARP CORNERS WITH 0.40 mm.
3. TOLERANCES WILL BE AS PER IS:6477-1983 , UNLESS OTHERWISE SPECIFIED

PARTY'S NAME	AMMYS GLAZING, MUMBAI
PARTY'S DRAWING No.	AS PER AUTOCAD DRAWING
ALLOY & TEMPER	6063 T6
DESCRIPTION	WINDOW SECTION