

P-19261

S6182

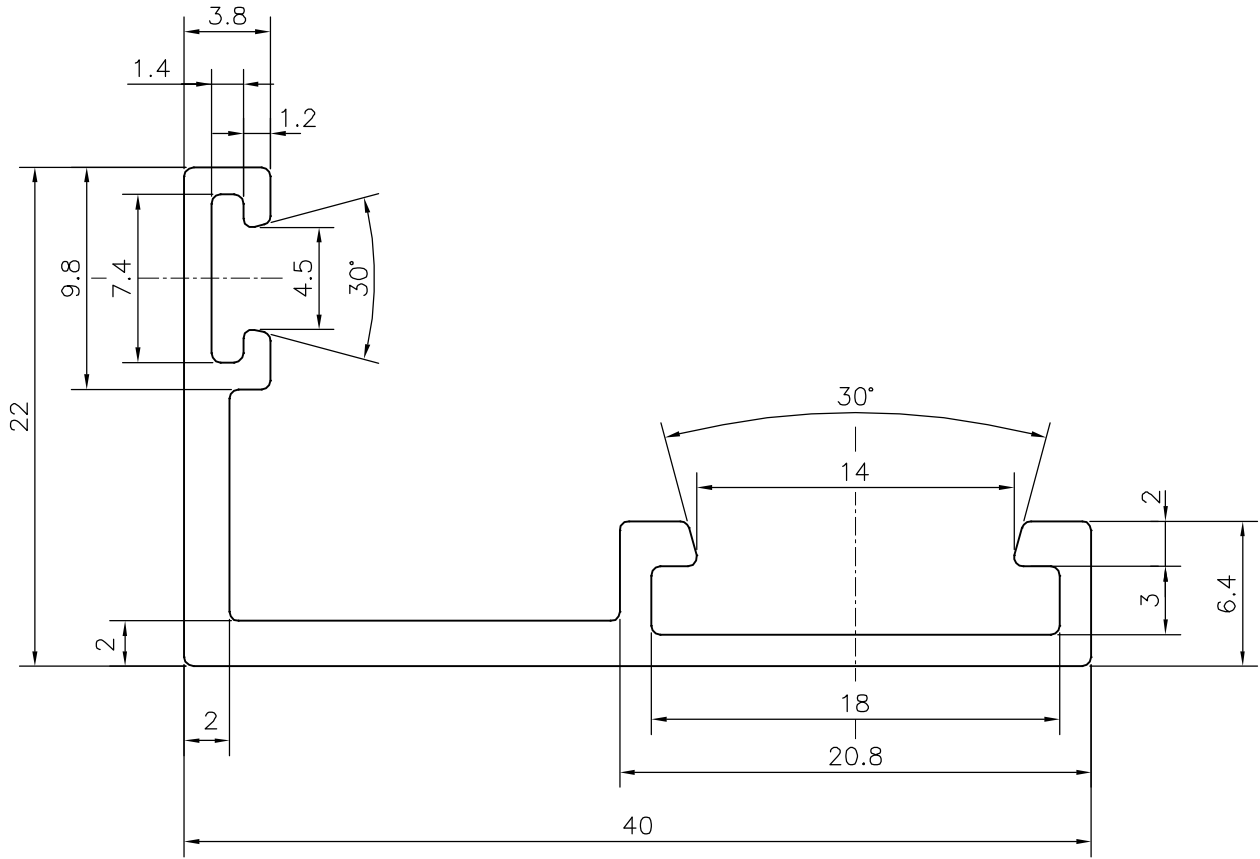
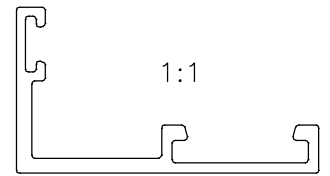

SYMBOL OF QUALITY
AN ISO 9001 COMPANY

JINDAL ALUMINIUM LTD.
BANGALORE-560073 (INDIA)

	NAME	DATE
DRAWN	J.P.KAUSHIK	08-03-2019
CHECKED		
APPROVED	B.NATARAJA	15-03-2019
SCALE		3:1
AREA mm ²		130.536
PERIMETER mm.		160.192
WEIGHT kg/m		0.352
DRAWING No.	SECTION No.	
P-19261	-	
S6182	S6182	

1. ALL DIMENSIONS ARE IN mm.
2. ROUND OFF ALL SHARP CORNERS WITH 0.40 mm.
3. TOLERANCES WILL BE AS PER IS:3965-1981 , UNLESS OTHERWISE SPECIFIED

PARTY'S NAME	GREENBUILD KONCEPTS, JAIPUR
PARTY'S DRAWING No.	AS PER DRAWING
ALLOY & TEMPER	6063 T6
DESCRIPTION	FRAME ADDON SECTION