

P-19279

S6194

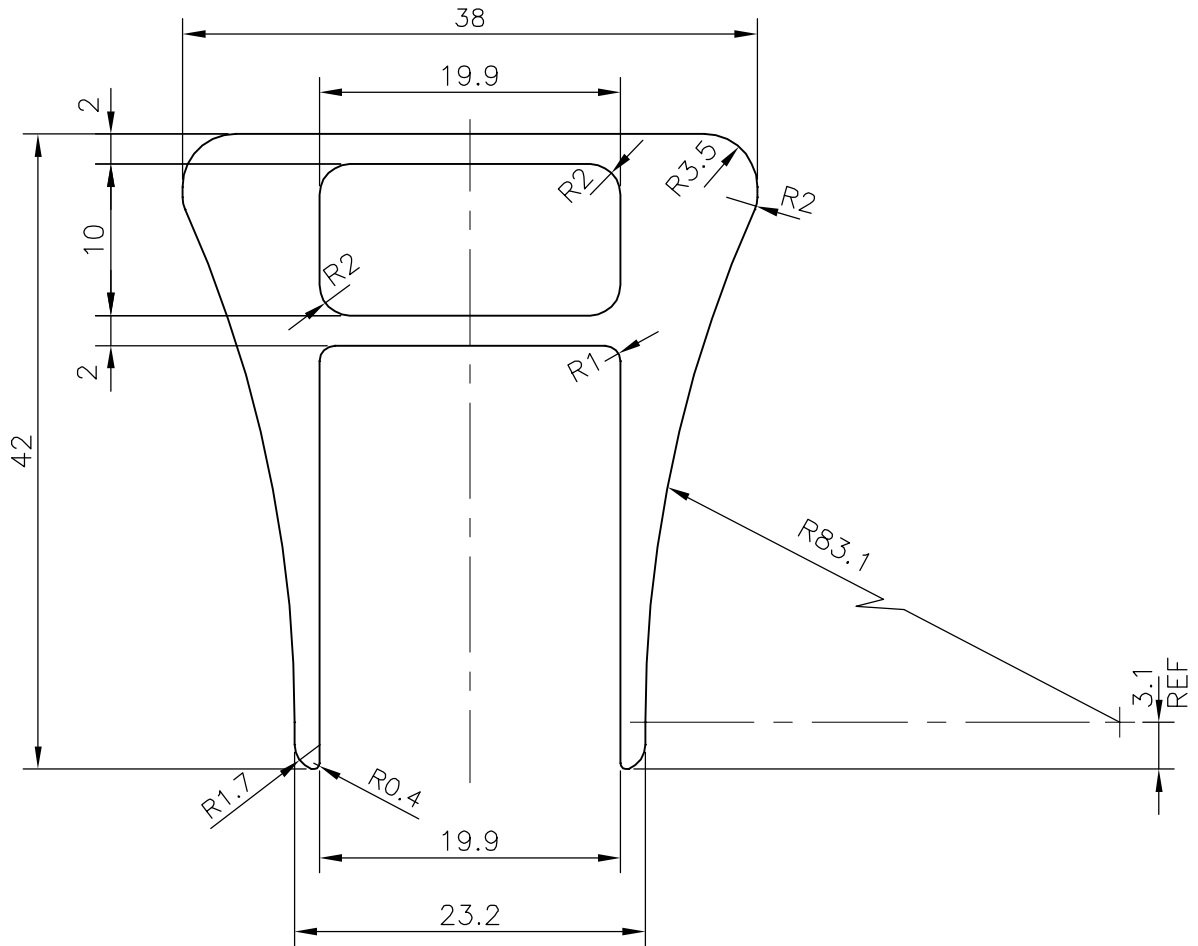
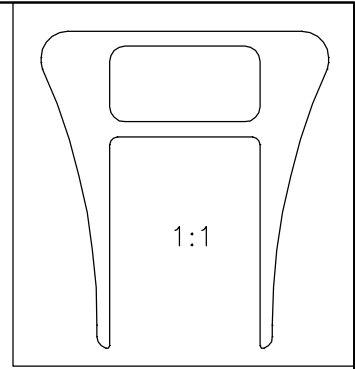

SYMBOL OF QUALITY  
AN ISO 9001 COMPANY

**JINDAL ALUMINIUM LTD.**  
BANGALORE-560073 (INDIA)

	NAME	DATE
DRAWN	J.P.KAUSHIK	14-03-2019
CHECKED		
APPROVED	B.NATARAJA	25-03-2019

1. ALL DIMENSIONS ARE IN mm.
2. ROUND OFF ALL SHARP CORNERS WITH 0.40 mm.
3. TOLERANCES WILL BE AS PER IS:6477-1983 , UNLESS OTHERWISE SPECIFIED

SCALE	2:1
AREA mm <sup>2</sup>	450.047
PERIMETER mm.	197.761
WEIGHT kg/m	1.215

PARTY'S NAME	ALUVITRO SYSTEMS PVT. LTD., THANE
PARTY'S DRAWING No.	AS PER AutoCAD DRAWING
ALLOY & TEMPER	6063 T6
DESCRIPTION	HANDRAIL SECTION

DRAWING No.	SECTION No.
P-19279	-
S6194	S6194