

P-19368

S6200

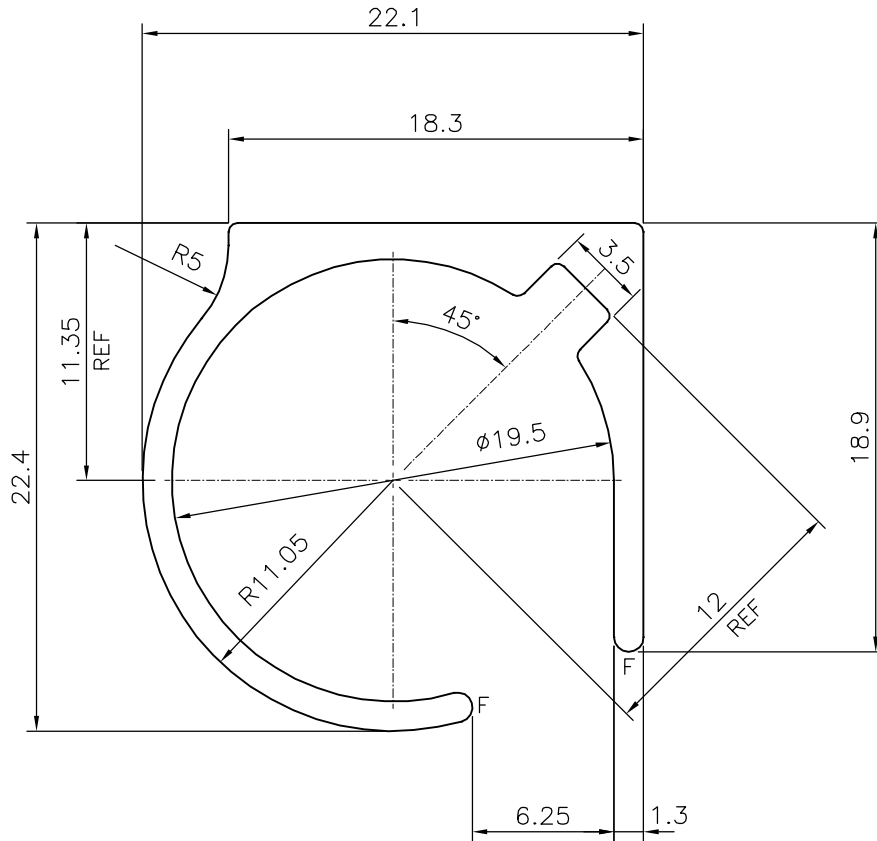

F= FULL RADIUS (2 PLACES)

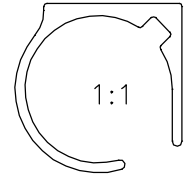

SYMBOL OF QUALITY
AN ISO 9001 COMPANY

JINDAL ALUMINIUM LTD.
BANGALORE-560073 (INDIA)

	NAME	DATE
DRAWN	J.P.KAUSHIK	01-04-2019
CHECKED		
APPROVED	B.NATARAJA	08-04-2019
SCALE		3:1
AREA mm ²		108.008
PERIMETER mm.		132.763
WEIGHT kg/m		0.292
DRAWING No.	SECTION No.	
P-19368	-	
S6200	S6200	

1. ALL DIMENSIONS ARE IN mm.
2. ROUND OFF ALL SHARP CORNERS WITH 0.40 mm.
3. TOLERANCES WILL BE AS PER IS:3965-1981 UNLESS OTHERWISE SPECIFIED

PARTY'S NAME	VISION INNOVATIVE TECHNOLOGIES, BANGALORE
PARTY'S DRAWING No.	AS PER SAMPLE
ALLOY & TEMPER	6063 T6
DESCRIPTION	MISC. SECTION