

P-19343-2

S6202

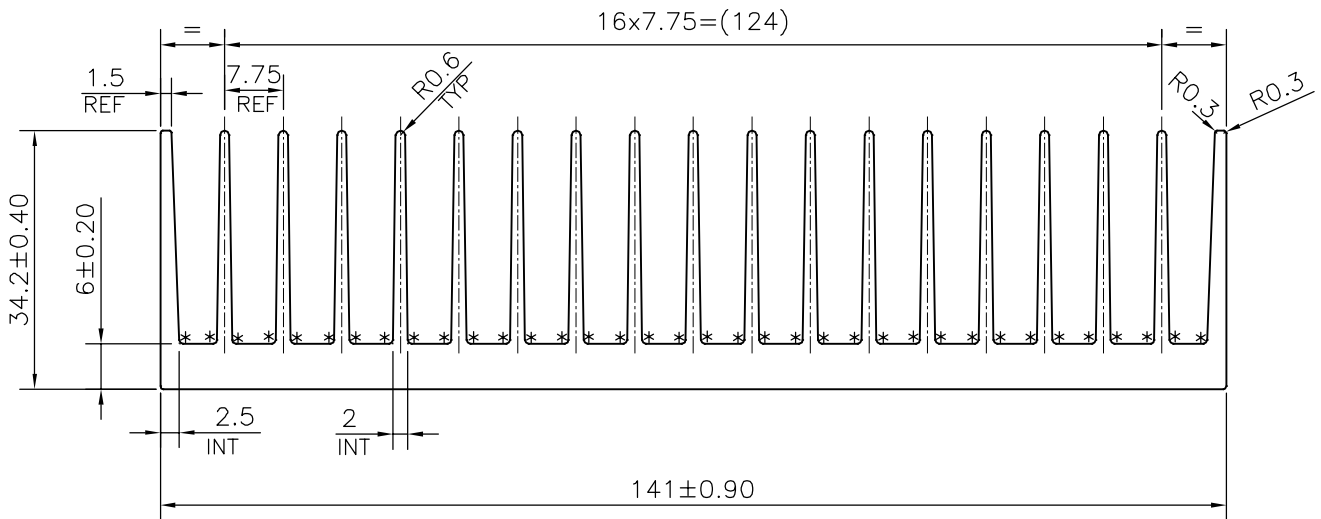

FLATNESS: -0.80 mm ON 141 mm WIDTH

* = 0.50 RADIUS (36 PLACES)



SYMBOL OF QUALITY
AN ISO 9001 COMPANY

JINDAL ALUMINIUM LTD.
BANGALORE-560073 (INDIA)

	NAME	DATE
DRAWN	J.P.KAUSHIK	04-04-2019
CHECKED		
APPROVED	B.NATARAJA	10-04-2019
SCALE		1:1
AREA mm ²		1720.584
PERIMETER mm.		1333.072
WEIGHT kg/m		4.646
DRAWING No.	SECTION No.	
P-19343-2	-	
S6202	S6202	

1. ALL DIMENSIONS ARE IN mm.
2. ROUND OFF ALL SHARP CORNERS WITH 0.40 mm.
3. TOLERANCES WILL BE AS PER IS:3965-1981, UNLESS OTHERWISE SPECIFIED

PARTY'S NAME	AVID THERMALLOY INDIA PVT. LTD., VADODARA
PARTY'S DRAWING No.	AS PER DRAWING-400972-A
ALLOY & TEMPER	6060 T5
DESCRIPTION	HEAT SINK SECTION