

P-19390

S6210

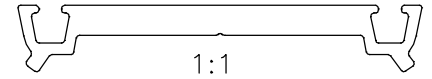

1:1

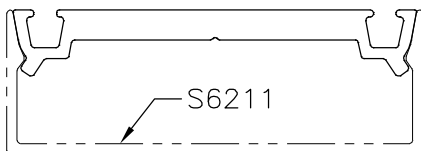
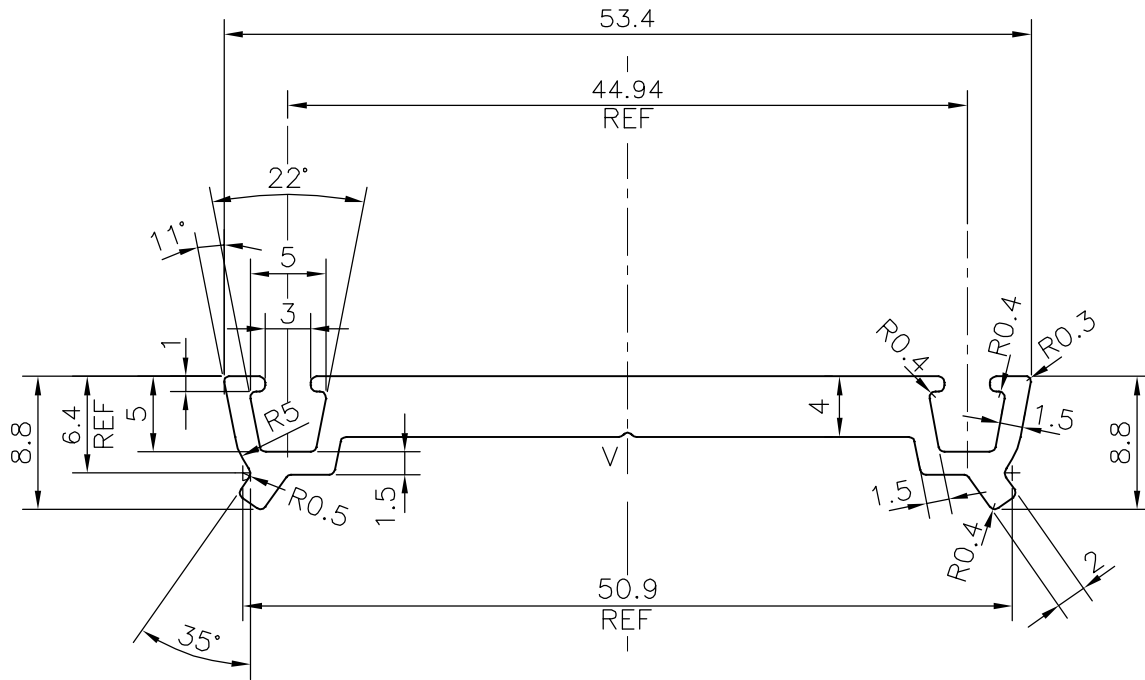

S6211



S6209

V = V GROOVE 0.3x90° (1 PLACE)



SYMBOL OF QUALITY
AN ISO 9001 COMPANY

JINDAL ALUMINIUM LTD.
BANGALORE-560073 (INDIA)

	NAME	DATE
DRAWN	J.P.KAUSHIK	09-04-2019
CHECKED		
APPROVED	B.NATARAJA	17-04-2019
SCALE		2:1
AREA mm ²		210.457
PERIMETER mm.		150.983
WEIGHT kg/m		0.568
DRAWING No.	SECTION No.	
P-19390	-	
S6210	S6210	

1. ALL DIMENSIONS ARE IN mm.
2. ROUND OFF ALL SHARP CORNERS WITH 0.40 mm.
3. TOLERANCES WILL BE AS PER IS:3965-1981 UNLESS OTHERWISE SPECIFIED

PARTY'S NAME	MASCOT ENGG. WORKS, MUMBAI
PARTY'S DRAWING No.	AS PER DRAWING
ALLOY & TEMPER	6063 T6
DESCRIPTION	PRESSURE PLATE-CURTAIN WALL