

P-19391

S6211

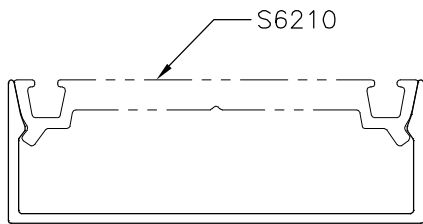
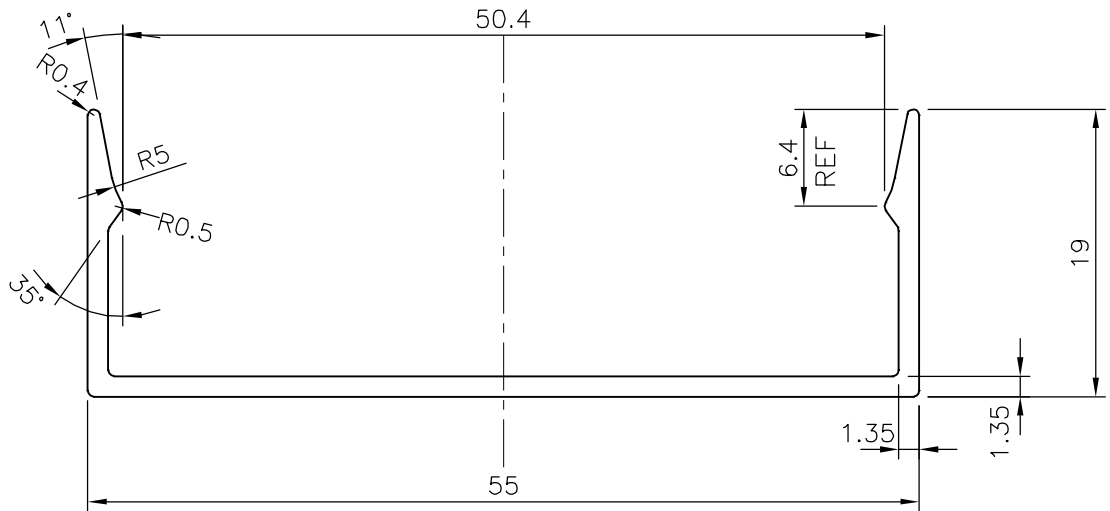
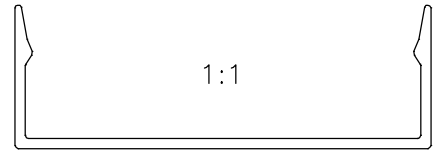

SYMBOL OF QUALITY
AN ISO 9001 COMPANY

JINDAL ALUMINIUM LTD.
BANGALORE-560073 (INDIA)

	NAME	DATE
DRAWN	J.P.KAUSHIK	09-04-2019
CHECKED		
APPROVED	B.NATARAJA	17-04-2019

1. ALL DIMENSIONS ARE IN mm.
2. ROUND OFF ALL SHARP CORNERS WITH 0.40 mm.
3. TOLERANCES WILL BE AS PER IS:3965-1981 UNLESS OTHERWISE SPECIFIED

SCALE	2:1
AREA mm ²	123.89
PERIMETER mm.	181.819
WEIGHT kg/m	0.335

PARTY'S NAME: MASCOT ENGG. WORKS, MUMBAI

PARTY'S DRAWING No.: AS PER DRAWING

ALLOY & TEMPER: 6063 T6

DESCRIPTION: COVER PLATE- CURTAIN WALL

DRAWING No.	SECTION No.
P-19391	-
S6211	S6211