

P-19375

S6215

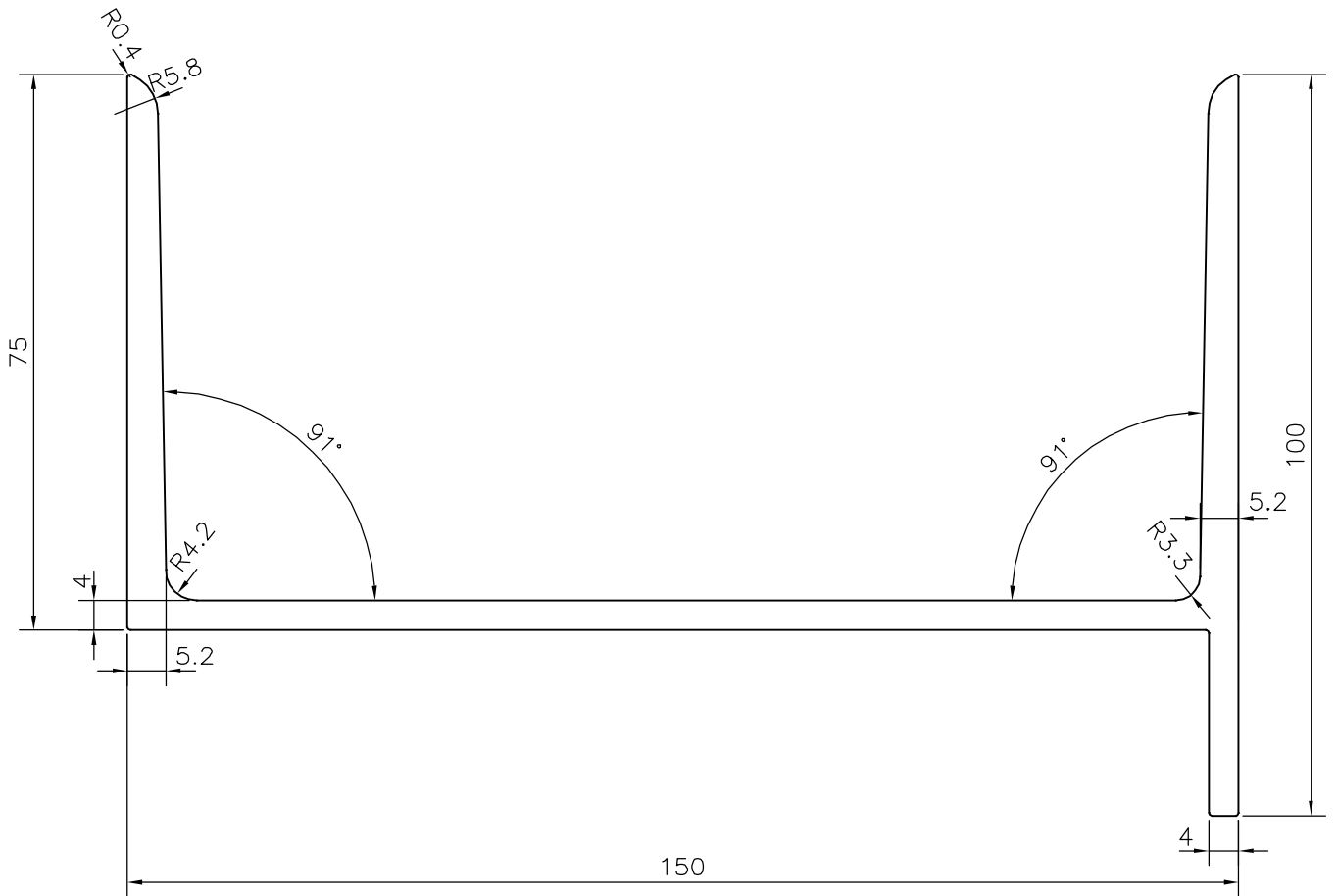
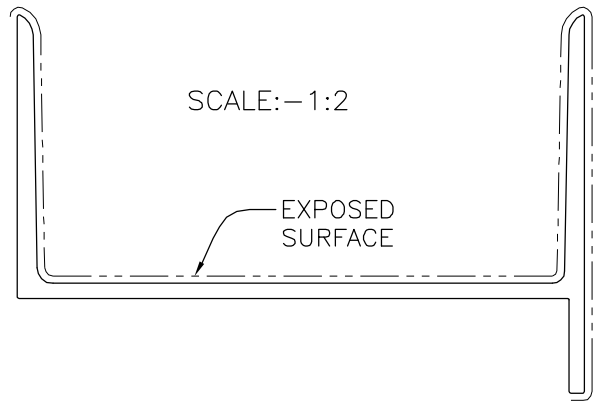

SYMBOL OF QUALITY  
AN ISO 9001 COMPANY

**JINDAL ALUMINIUM LTD.**  
BANGALORE-560073 (INDIA)

|                      | NAME        | DATE       |
|----------------------|-------------|------------|
| DRAWN                | J.P.KAUSHIK | 03-04-2019 |
| CHECKED              |             |            |
| APPROVED             | B.NATARAJA  | 19-04-2019 |
| SCALE                |             | 1:1        |
| AREA mm <sup>2</sup> |             | 1355.05    |
| PERIMETER mm.        |             | 631.352    |
| WEIGHT kg/m          |             | 3.659      |
| DRAWING No.          | SECTION No. |            |
| P-19375              | -           |            |
| S6215                | S6215       |            |
|                      |             |            |
|                      |             |            |

1. ALL DIMENSIONS ARE IN mm.
2. ROUND OFF ALL SHARP CORNERS WITH 0.40 mm.
3. TOLERANCES WILL BE AS PER IS:3965-1981 UNLESS OTHERWISE SPECIFIED

|                     |                       |
|---------------------|-----------------------|
| PARTY'S NAME        | KAMLESH B JHALA, PUNE |
| PARTY'S DRAWING No. | AS PER DRAWING        |
| ALLOY & TEMPER      | HE9 WP                |
| DESCRIPTION         | MISC. CHANNEL         |