

P-18130-1

S6271

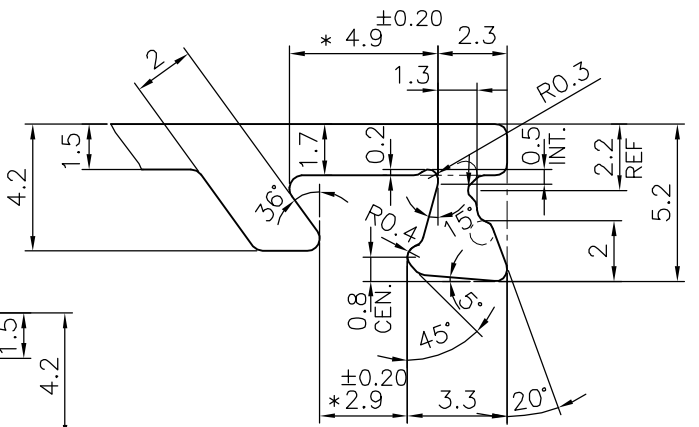
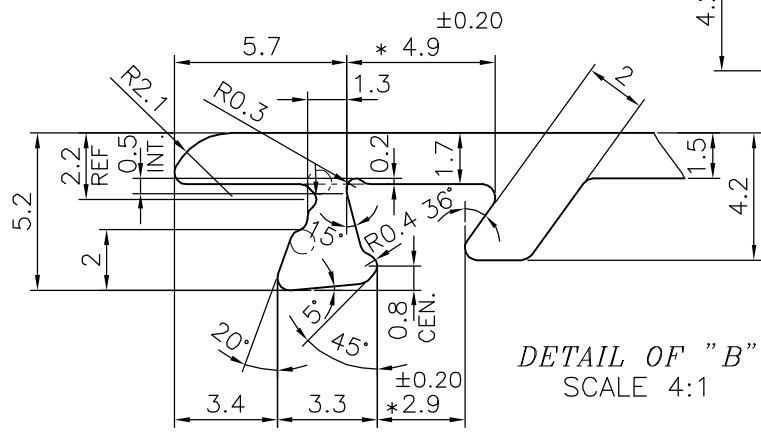
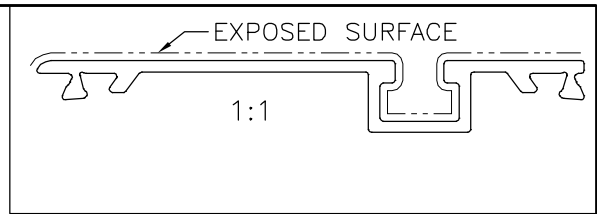

DETAIL OF "A"
SCALE 4:1

DETAIL OF "B"
SCALE 4:1

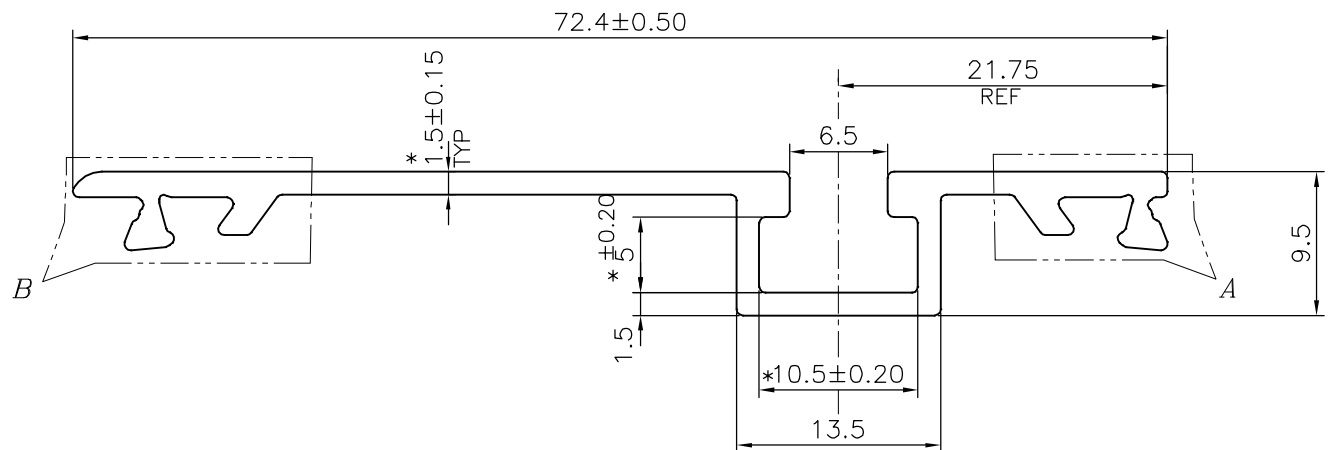

* = MARKED DIMENSIONS ARE CRITICAL

TOLERANCES ON OVERALL WIDTHS & WIDTHS ACROSS FLATS OF BARS, & REGULAR SECTIONS

UPTO 6.40mm - ±0.20	UPTO 32.0mm - ±0.38	UPTO 120.0mm - ±0.85	UPTO 320.00mm - ±1.70
UPTO 10.0mm - ±0.23	UPTO 50.0mm - ±0.46	UPTO 160.0mm - ±1.02	
UPTO 12.0mm - ±0.25	UPTO 60.0mm - ±0.53	UPTO 200.0mm - ±1.14	
UPTO 16.0mm - ±0.28	UPTO 80.0mm - ±0.69	UPTO 250.0mm - ±1.40	
UPTO 25.0mm - ±0.30	UPTO 100.0mm - ±0.75	UPTO 300.0mm - ±1.65	

 SYMBOL OF QUALITY AN ISO 9001 COMPANY	JINDAL ALUMINIUM LTD. BANGALORE-560073 (INDIA)	NAME	DATE
		DRAWN	J.P.KAUSHIK 04-05-2019
		CHECKED	
		APPROVED	B.NATARAJA 01-06-2019
1. ALL DIMENSIONS ARE IN mm. 2. ROUND OFF ALL SHARP CORNERS WITH 0.40 mm. 3. TOLERANCES WILL BE AS PER IS:3965-1981, UNLESS OTHERWISE SPECIFIED		SCALE	2:1
		AREA mm ²	175.256
		PERIMETER mm.	212.947
		WEIGHT kg/m	0.473
		DRAWING No.	SECTION No.
PARTY'S NAME	VIVANT SOLUTION PVT. LTD., CHENNAI	P-18130-1	-
PARTY'S DRAWING No.	VS350-251	S6271	S6271
ALLOY & TEMPER	6063 T6		
DESCRIPTION	AIR GRILL SECTION		