

P-19442

S6273

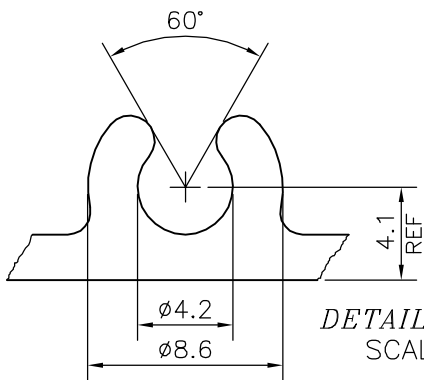
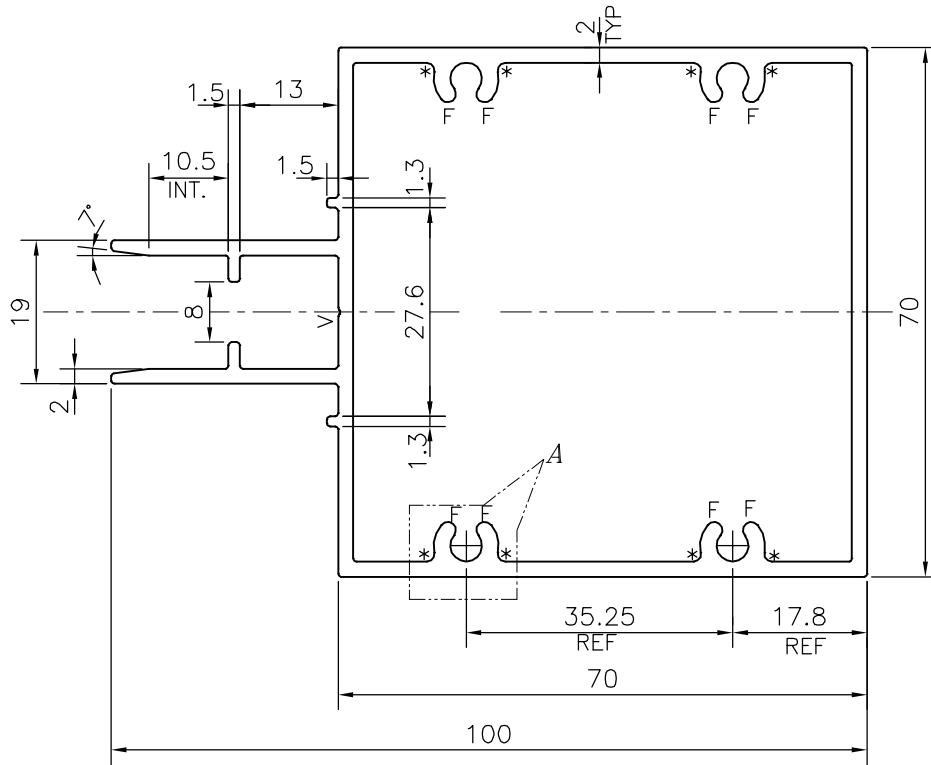

DETAIL OF "A"  
SCALE 3:1

V = V GROOVE 0.3x90° (1 PLACE)  
F = FULL RADIUS (8 PLACES)  
\* = 1.0 RADIUS (8 PLACES)



SYMBOL OF QUALITY  
AN ISO 9001 COMPANY

**JINDAL ALUMINIUM LTD.**  
BANGALORE-560073 (INDIA)

	NAME	DATE
DRAWN	J.P.KAUSHIK	22-04-2019
CHECKED		
APPROVED	B.NATARAJA	04-06-2019
SCALE		1:1
AREA	mm <sup>2</sup>	774.524
PERIMETER	mm.	414.315
WEIGHT	kg/m	2.091
DRAWING No.	SECTION No.	
P-19442	-	
S6273	S6273	

1. ALL DIMENSIONS ARE IN mm.
2. ROUND OFF ALL SHARP CORNERS WITH 0.40 mm.
3. TOLERANCES WILL BE AS PER IS:6477-1983 UNLESS OTHERWISE SPECIFIED

PARTY'S NAME	RELCON INFRA PROJECTS LTD., MUMBAI
PARTY'S DRAWING No.	AS PER DRAWING
ALLOY & TEMPER	6063 T6
DESCRIPTION	CURTAIN WALL SECTION