

P-19608-1

S6275

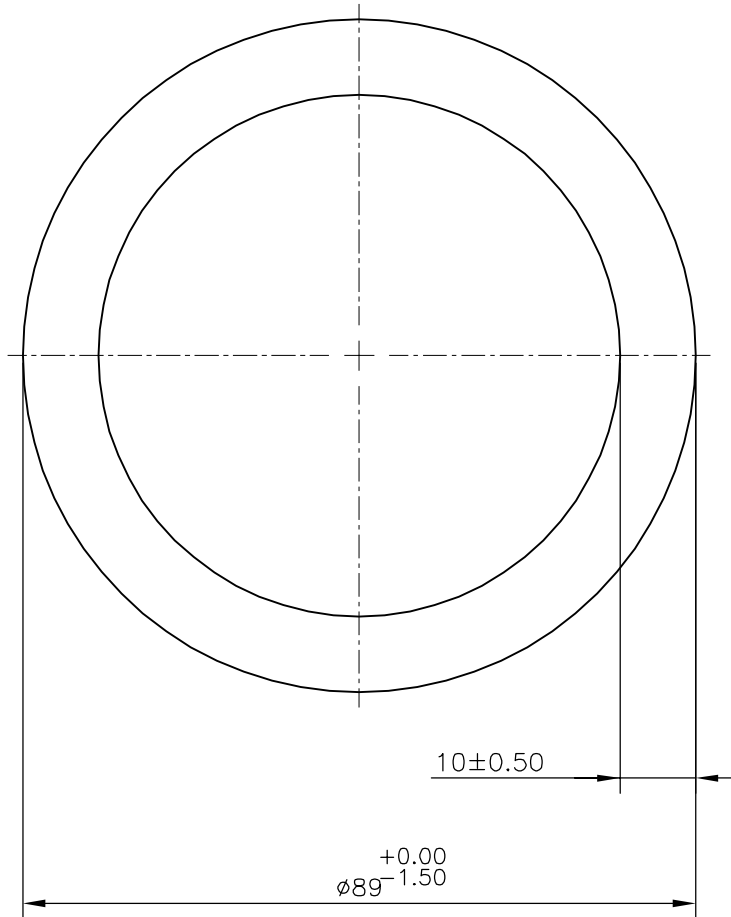

TWIST & BEND=1.5mm/M
 OVALITY : $\pm 1.0\%$ OF DIA



SYMBOL OF QUALITY
 AN ISO 9001 COMPANY

JINDAL ALUMINIUM LTD.
 BANGALORE-560073 (INDIA)

	NAME	DATE
DRAWN	J.P.KAUSHIK	03-06-2019
CHECKED		
APPROVED	B.NATARAJA	06-06-2019
SCALE		1:1
AREA mm ²		2481.858
PERIMETER mm.		279.602
WEIGHT kg/m		6.701
DRAWING No.	SECTION No.	
P-19608-1	-	
S6275	S6275	

1. ALL DIMENSIONS ARE IN mm.
2. ROUND OFF ALL SHARP CORNERS WITH 0.40 mm.
3. TOLERANCES WILL BE AS PER IS:2673-2002 , UNLESS OTHERWISE SPECIFIED

PARTY'S NAME	GR POWER SWITCHGEAR LTD., HYDERABAD
PARTY'S DRAWING No.	AS PER SPECIFICATION
ALLOY & TEMPER	63401 WP
DESCRIPTION	ROUND TUBE