

P-19602-1

S6289

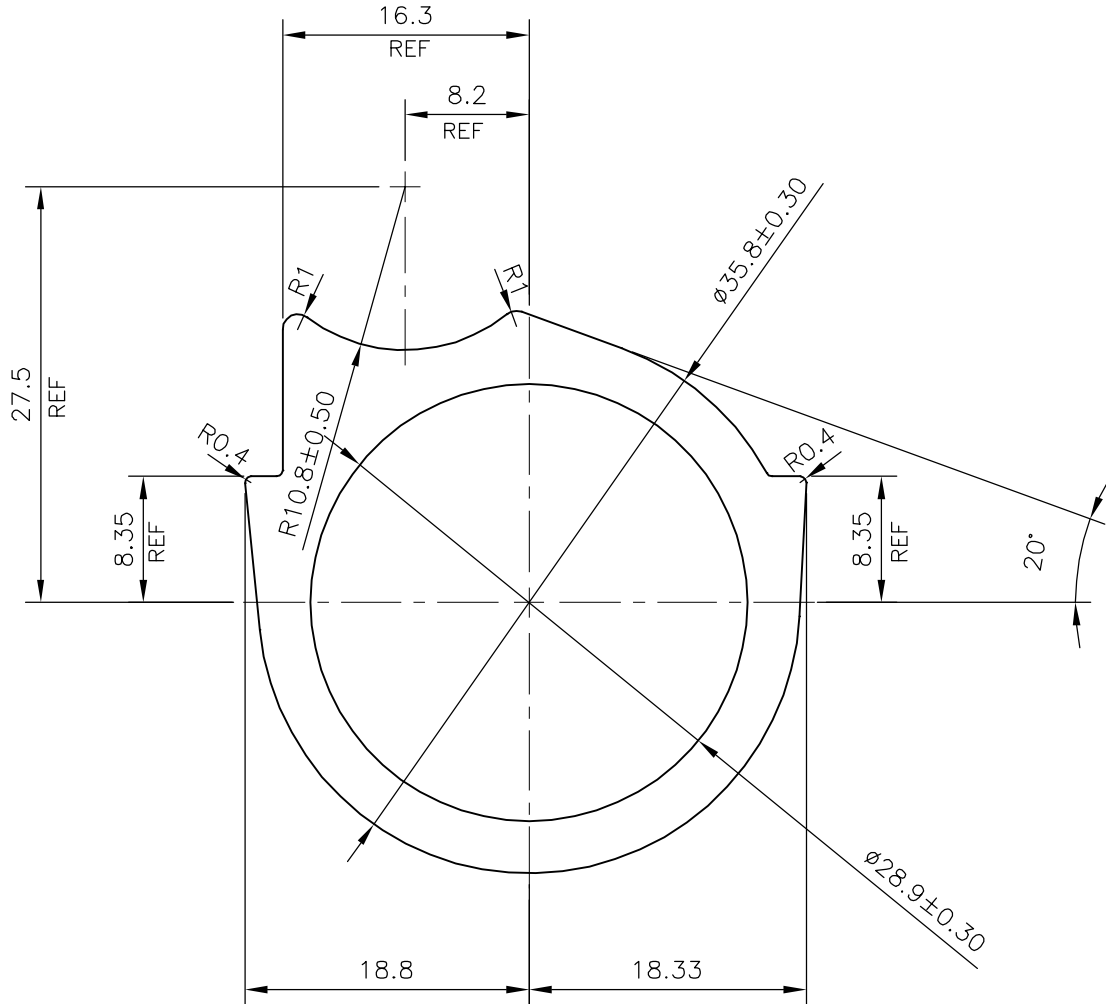
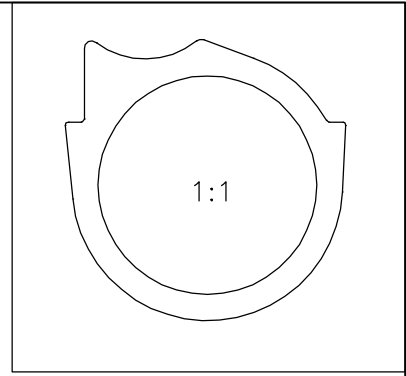

SYMBOL OF QUALITY
AN ISO 9001 COMPANY

JINDAL ALUMINIUM LTD.
BANGALORE-560073 (INDIA)

	NAME	DATE
DRAWN	J.P.KAUSHIK	04-06-2019
CHECKED		
APPROVED	B.NATARAJA	14-06-2019
SCALE		2:1
AREA mm ²		415.627
PERIMETER mm.		124.867
WEIGHT kg/m		1.122
DRAWING No.	SECTION No.	
P-19602-1	-	
S6289	S6289	

1. ALL DIMENSIONS ARE IN mm.
2. ROUND OFF ALL SHARP CORNERS WITH 0.40 mm.
3. TOLERANCES WILL BE AS PER IS:6477-1983 UNLESS OTHERWISE SPECIFIED

PARTY'S NAME	SHUBHANGAD INDUSTRIES, PUNE
PARTY'S DRAWING No.	AS PER DRAWING
ALLOY & TEMPER	3103 'F'
DESCRIPTION	KOMO PROFILE