

P-19641

S6303

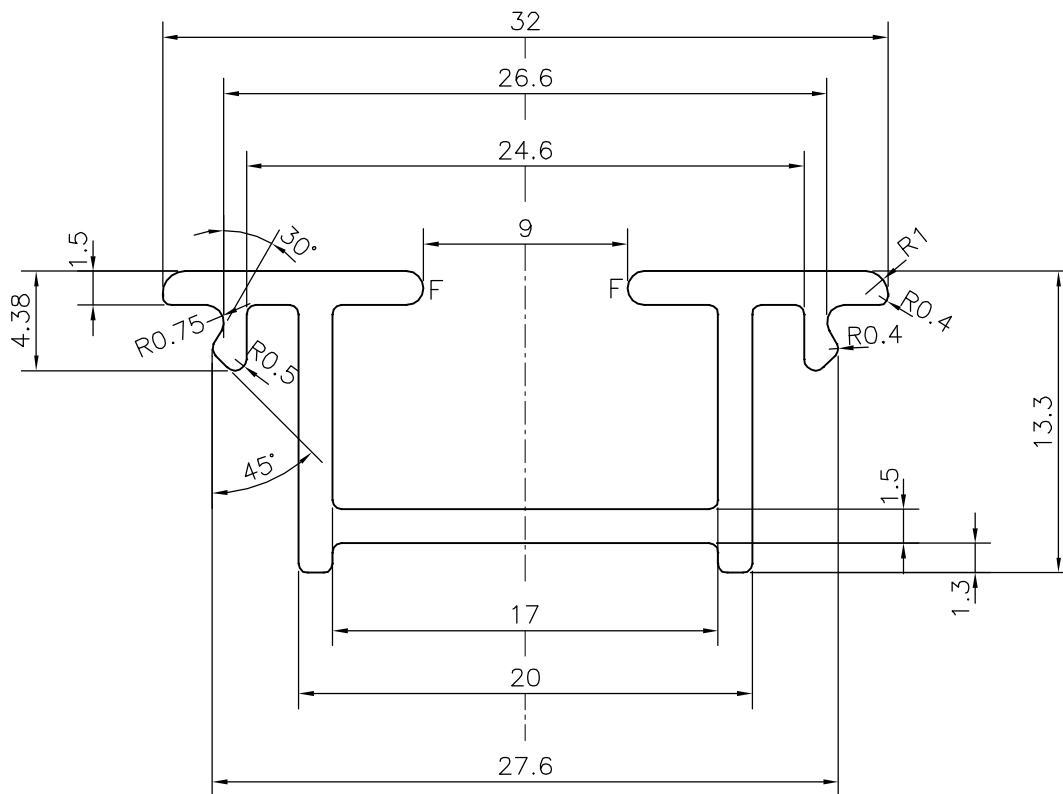

F = FULL RADIUS (2 PLACES)

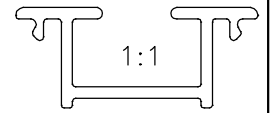

SYMBOL OF QUALITY
AN ISO 9001 COMPANY

JINDAL ALUMINIUM LTD.
BANGALORE-560073 (INDIA)

	NAME	DATE
DRAWN	J.P.KAUSHIK	13-06-2019
CHECKED		
APPROVED	B.NATARAJA	20-06-2019
SCALE		3:1
AREA mm ²		101.382
PERIMETER mm.		135.998
WEIGHT kg/m		0.274
DRAWING No.	SECTION No.	
P-19641	-	
S6303	S6303	

1. ALL DIMENSIONS ARE IN mm.
2. ROUND OFF ALL SHARP CORNERS WITH 0.40 mm.
3. TOLERANCES WILL BE AS PER IS:3965-1981 , UNLESS OTHERWISE SPECIFIED

PARTY'S NAME	OM SAI INTERIORS PVT. LTD., PUNE
PARTY'S DRAWING No.	AS PER DRAWING
ALLOY & TEMPER	6063 T6
DESCRIPTION	CLIP SECTION