

P-19580

S6316

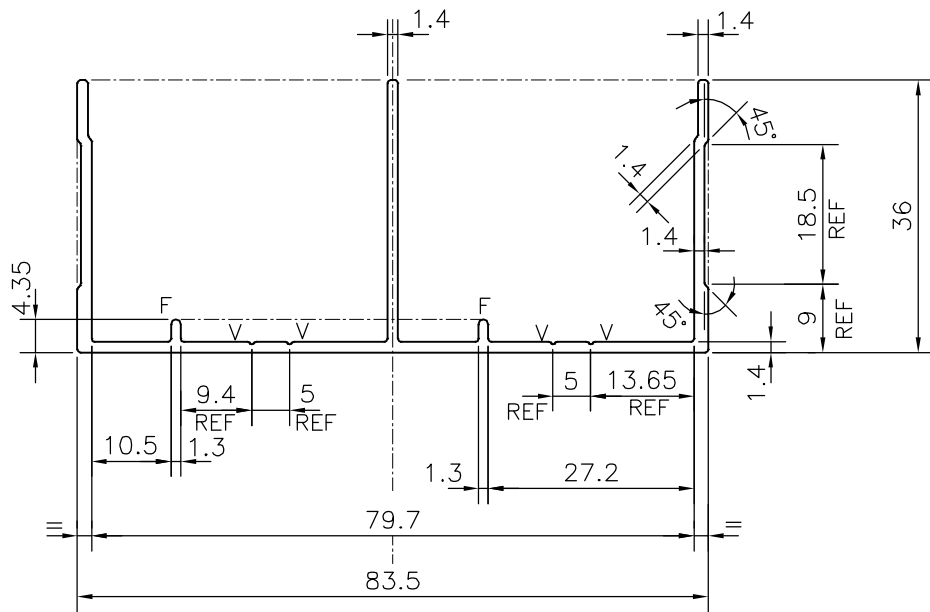

V = V GROOVE 0.3x90° (4 PLACES)
 F = FULL RADIUS (2 PLACES)



SYMBOL OF QUALITY
 AN ISO 9001 COMPANY

JINDAL ALUMINIUM LTD.
 BANGALORE-560073 (INDIA)

		NAME	DATE
DRAWN	J.P.KAUSHIK		28-05-2019
CHECKED			
APPROVED	B.NATARAJA		27-06-2019
SCALE			1:1
AREA	mm ²		276.787
PERIMETER	mm.		386.126
WEIGHT	kg/m		0.747
DRAWING No.		SECTION No.	
P-19580		-	
S6316		S6316	

1. ALL DIMENSIONS ARE IN mm.
2. ROUND OFF ALL SHARP CORNERS WITH 0.40 mm.
3. TOLERANCES WILL BE AS PER IS:3965-1981, UNLESS OTHERWISE SPECIFIED

PARTY'S NAME	KRISHNA HARDWARE, BHIWANDI
PARTY'S DRAWING No.	AS PER SAMPLE
ALLOY & TEMPER	6063 T6
DESCRIPTION	MISC. SECTION