

P-19649

S6320

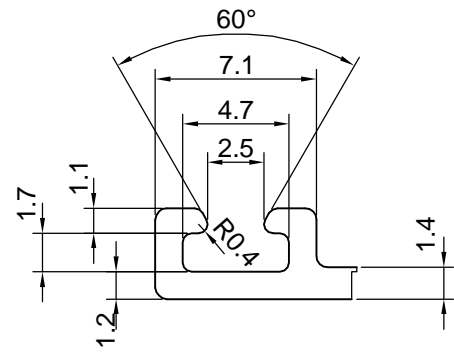

DETAIL OF "A"  
SCALE 3:1

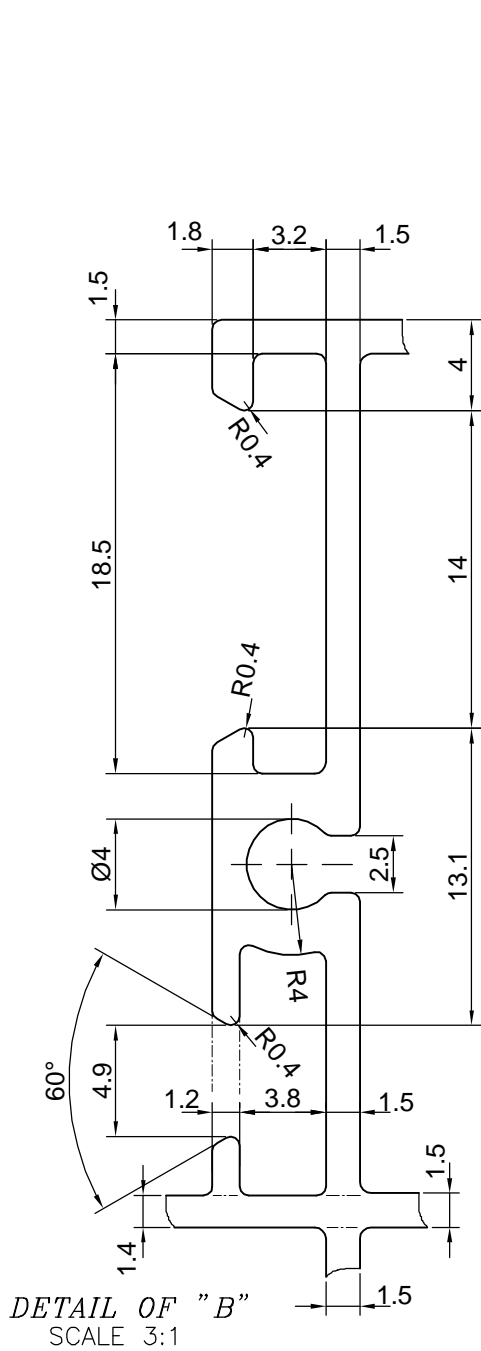
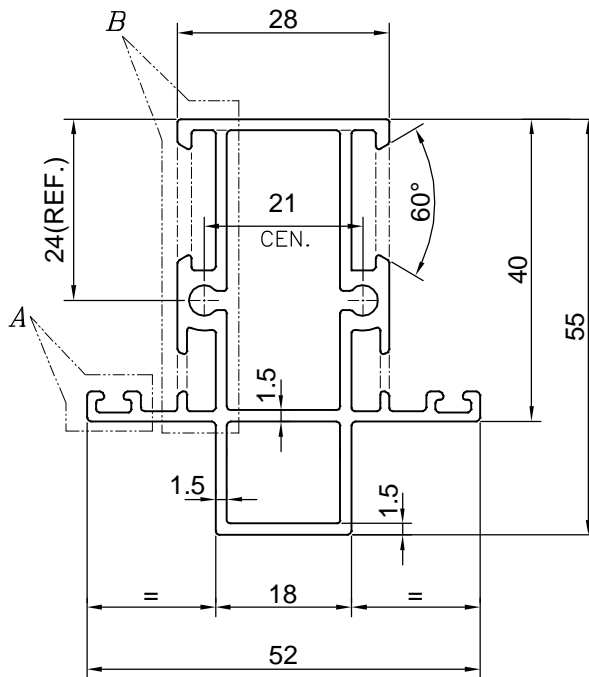

DETAIL OF "B"  
SCALE 3:1



SYMBOL OF QUALITY  
AN ISO 9001 COMPANY

**JINDAL ALUMINIUM LTD.**  
BANGALORE-560073 (INDIA)

	NAME	DATE
DRAWN	J.P.KAUSHIK	14-06-2019
CHECKED		
APPROVED	B.NATARAJA	28-06-2019

1. ALL DIMENSIONS ARE IN mm.
2. ROUND OFF ALL SHARP CORNERS WITH 0.40 mm.
3. TOLERANCES WILL BE AS PER IS:6477-1983, UNLESS OTHERWISE SPECIFIED

SCALE	1:1
AREA mm <sup>2</sup>	385.85
PERIMETER mm.	312.247
WEIGHT kg/m	1.042

PARTY'S NAME	HATIM GLAZING & CLADDING PVT LTD., MUMBAI
PARTY'S DRAWING No.	AS PER DRAWING
ALLOY & TEMPER	6063 T6
DESCRIPTION	WINDOW SECTION

DRAWING No.	SECTION No.
P-19649	-
S6320	S6320