

P-19650

S6321

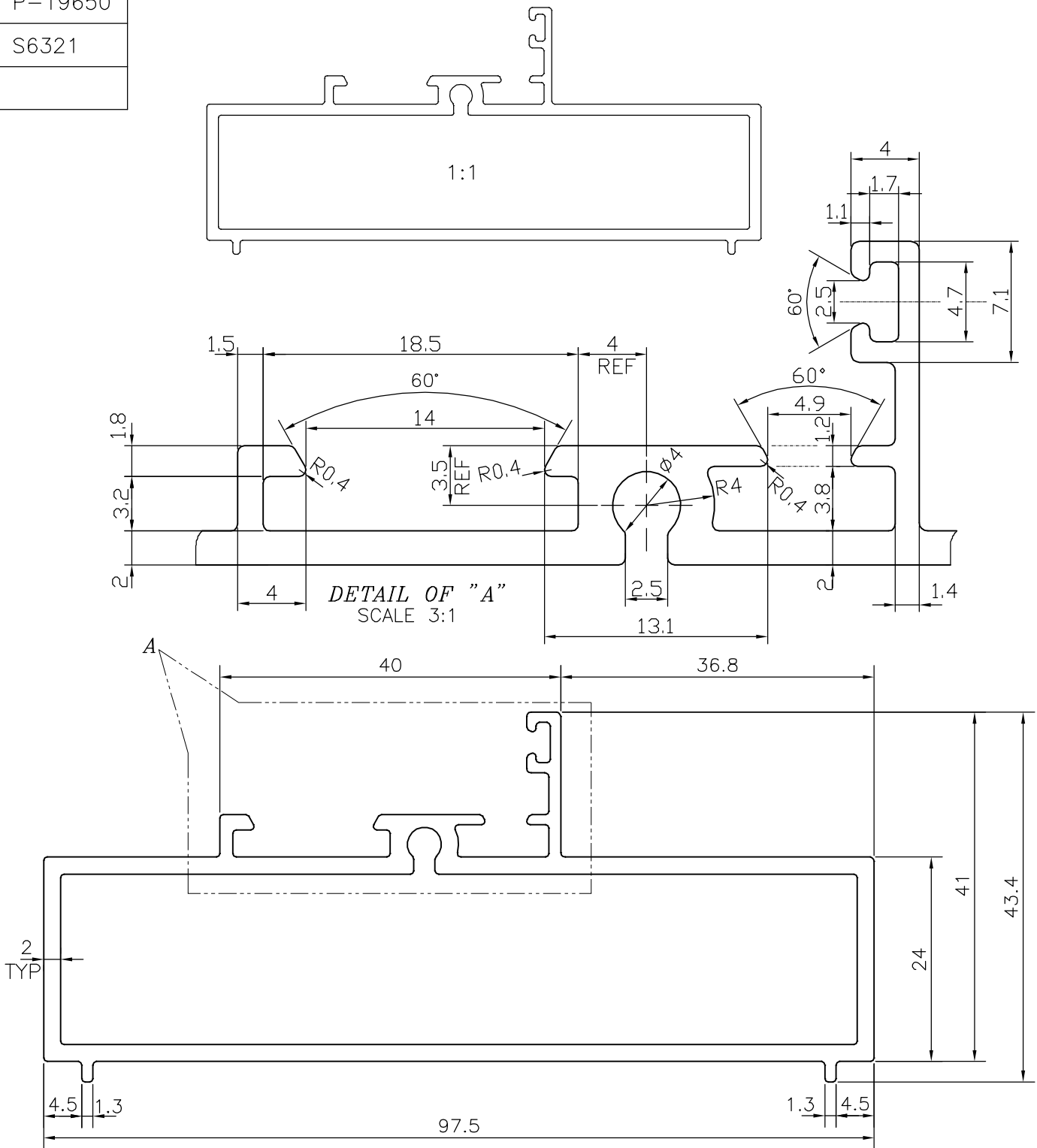

SYMBOL OF QUALITY
AN ISO 9001 COMPANY

JINDAL ALUMINIUM LTD.
BANGALORE-560073 (INDIA)

| | NAME | DATE |
|----------------------|-------------|------------|
| DRAWN | J.P.KAUSHIK | 14-06-2019 |
| CHECKED | | |
| APPROVED | B.NATARAJA | 28-06-2019 |
| SCALE | | 1.5:1 |
| AREA mm ² | | 551.546 |
| PERIMETER mm. | | 333.599 |
| WEIGHT kg/m | | 1.489 |
| DRAWING No. | SECTION No. | |
| P-19650 | - | |
| S6321 | S6321 | |

1. ALL DIMENSIONS ARE IN mm.
2. ROUND OFF ALL SHARP CORNERS WITH 0.40 mm.
3. TOLERANCES WILL BE AS PER IS:6477-1983 , UNLESS OTHERWISE SPECIFIED

| | |
|---------------------|--|
| PARTY'S NAME | HATIM GLAZING & CLADDING PVT. LTD., MUMBAI |
| PARTY'S DRAWING No. | AS PER DRAWING |
| ALLOY & TEMPER | 6063 T6 |
| DESCRIPTION | WINDOW SECTION |