

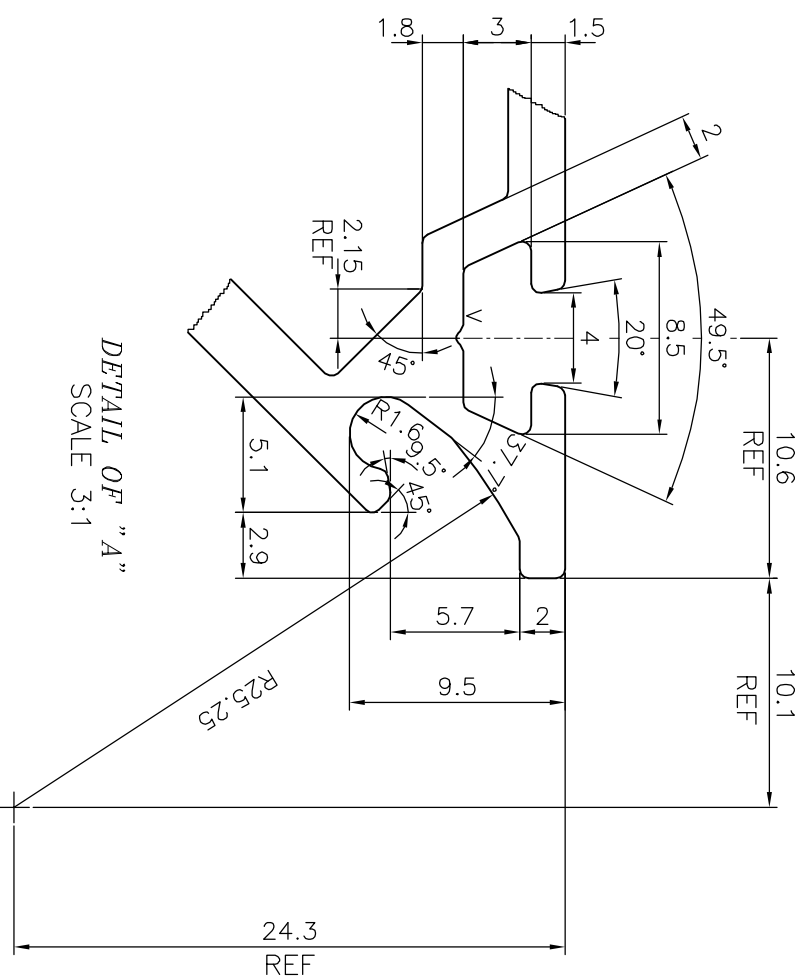

P-19506

S6325

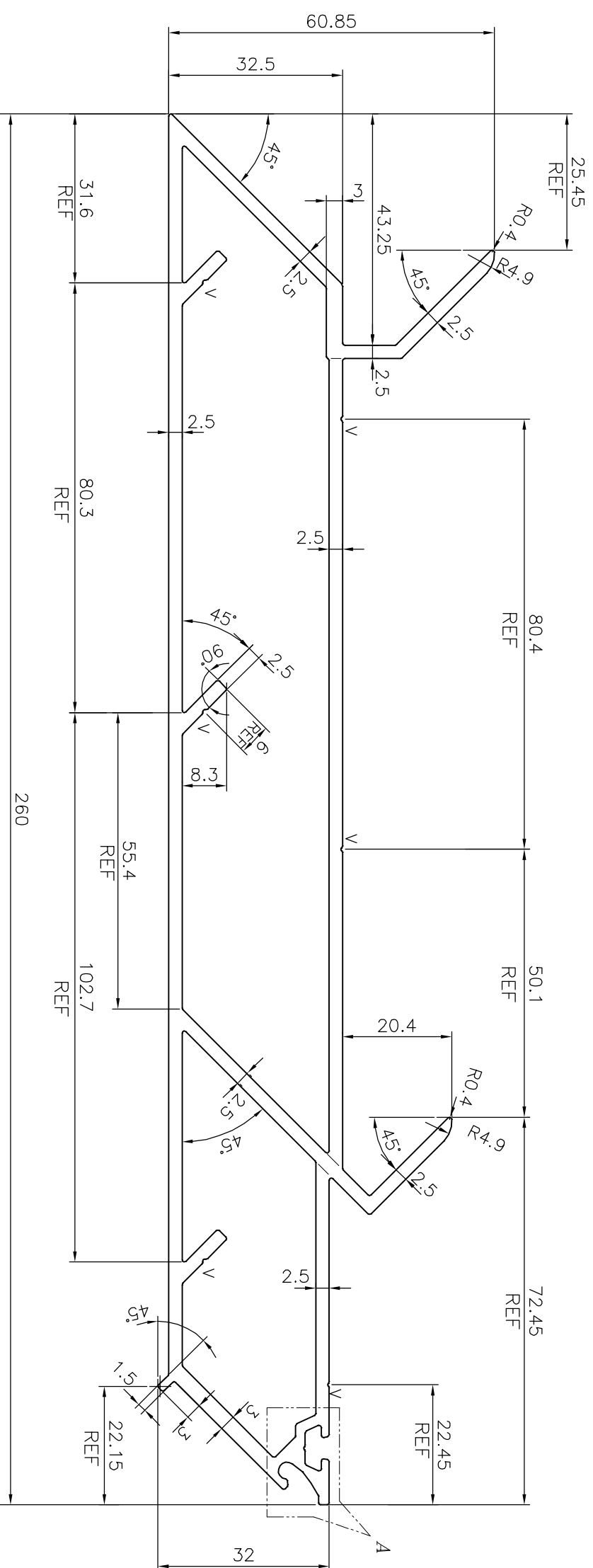

V = V GROOVE 0.3x90° (7 PLACES)

 SYMBOL OF QUALITY AN ISO 9001 COMPANY		JINDAL ALUMINIUM LTD. BANGALORE-560073 (INDIA)	
1. ALL DIMENSIONS ARE IN mm. 2. ROUND OFF ALL SHARP CORNERS WITH 0.40 mm. 3. TOLERANCES WILL BE AS PER IS:6477-1983 UNLESS OTHERWISE SPECIFIED		SCALE 1:1	
PARTY'S NAME ATS SAVVY DEVELOPERS LLP, AHMEDABAD		DRAWN J.P. KAUSHIK	
PARTY'S DRAWING No. AS PER DRAWING		CHECKED B. NATHARAJA	
ALLOY & TEMPER 6063 T6		APPROVED 01-07-2019	
DESCRIPTION CURTAIN WALL		AREA mm ² 1717.965	
		PERIMETER mm. 712.393	
		WEIGHT kg/m 4.639	
		DRAWING No. P-19506	
		SECTION No. -	
		S6325	
		S6325	