

P-19605-1

S6330

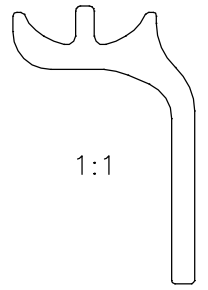

1:1

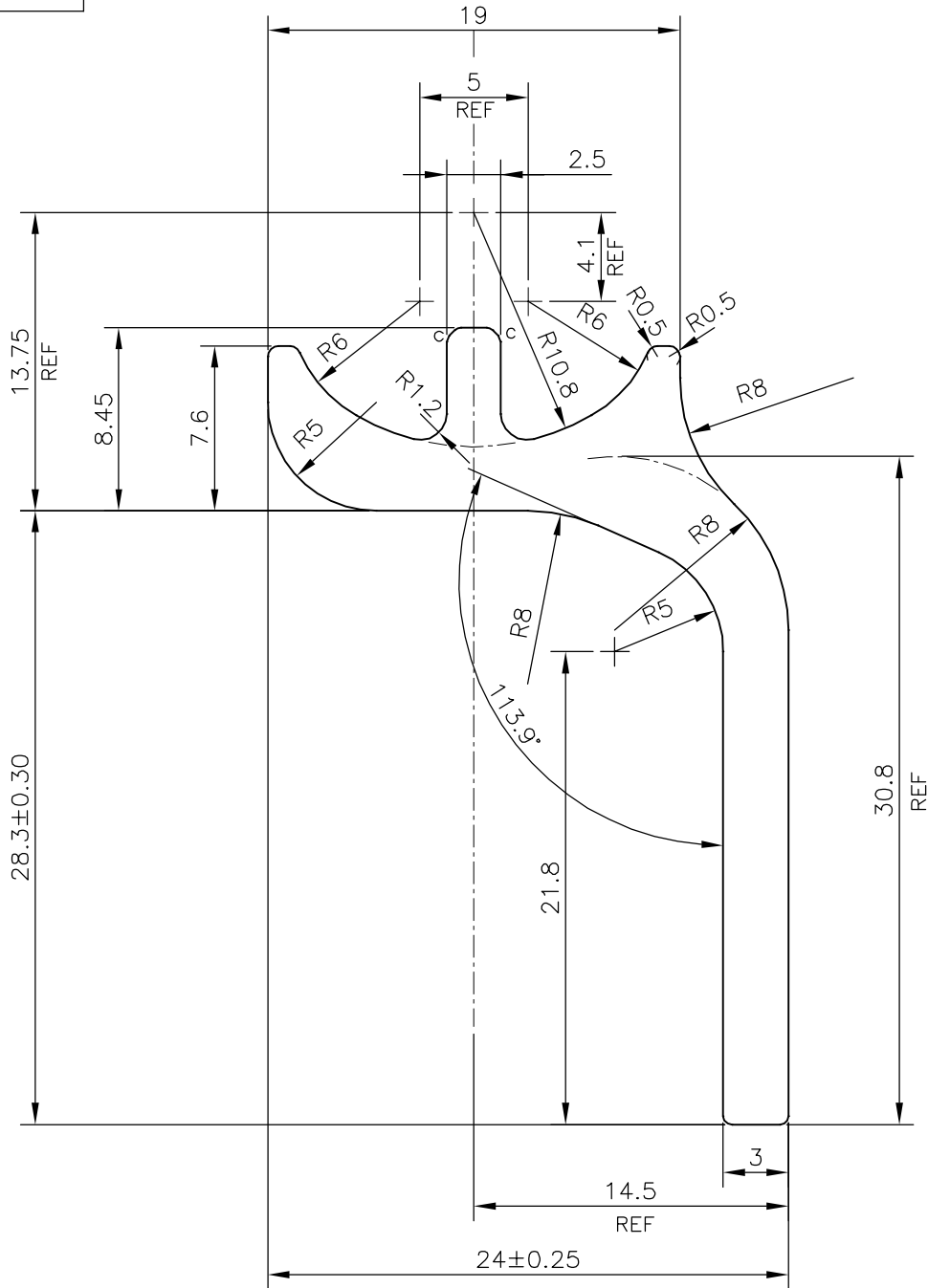

c = CHAMFER 0.5x45°(2 PLACES)



SYMBOL OF QUALITY
AN ISO 9001 COMPANY

JINDAL ALUMINIUM LTD.
BANGALORE-560073 (INDIA)

	NAME	DATE
DRAWN	J.P.KAUSHIK	21-06-2019
CHECKED		
APPROVED	B.NATARAJA	01-07-2019
SCALE		3:1
AREA mm ²		197.528
PERIMETER mm.		122.023
WEIGHT kg/m		0.533
DRAWING No.	SECTION No.	
P-19605-1	-	
S6330	S6330	

1. ALL DIMENSIONS ARE IN mm.
2. ROUND OFF ALL SHARP CORNERS WITH 0.40 mm.
3. TOLERANCES WILL BE AS PER IS:3965-1981 , UNLESS OTHERWISE SPECIFIED

PARTY'S NAME	YOONWOO AUTOMOTIVE INDIA PVT. LTD., PUNE
PARTY'S DRAWING No.	C50SC01/C50SE01 REV-A.01
ALLOY & TEMPER	6005 T5
DESCRIPTION	FORCE T1N BKT.LH RH EXT.